



Getting Started Guide

Powerdrive F300

Frame Sizes 3 to 10

Part Number: 0479-0002-01
Issue: 1



Original Instructions

For the purposes of compliance with the EU Machinery Directive 2006/42/EC.

General Information

This guide covers the basic information that is required to set-up and run the drive, in applications where a drive malfunction does not result in a mechanical hazard. When the drive is used in a safety related application, i.e. where a malfunction might result in a hazard, it is essential to refer to the full user guide. The *Drive User Guide* is available for download from www.controltechniques.com/userguides.

The manufacturer accepts no liability for any consequences resulting from inappropriate, negligent or incorrect installation or adjustment of the optional operating parameters of the equipment or from mismatching the variable speed drive with the motor.

The contents of this guide are believed to be correct at the time of printing. In the interests of a commitment to a policy of continuous development and improvement, the manufacturer reserves the right to change the specification of the product or its performance, or the contents of the guide, without notice.

All rights reserved. No parts of this guide may be reproduced or transmitted in any form or by any means, electrical or mechanical including photocopying, recording or by an information storage or retrieval system, without permission in writing from the publisher.

Drive firmware version

This product is supplied with the latest firmware version. If this drive is to be connected to an existing system or machine, all drive firmware versions should be verified to confirm the same functionality as drives of the same model already present. This may also apply to drives returned from a Control Techniques Service Centre or Repair Centre. If there is any doubt please contact the supplier of the product.

The firmware version of the drive can be checked by looking at Pr **11.029**

Environmental statement

Control Techniques is committed to minimising the environmental impacts of its manufacturing operations and of its products throughout their life cycle. To this end, we operate an Environmental Management System (EMS) which is certified to the International Standard ISO 14001. Further information on the EMS, our Environmental Policy and other relevant information is available on request, or can be found at www.greendrives.com.

The electronic variable-speed drives manufactured by Control Techniques have the potential to save energy and (through increased machine/process efficiency) reduce raw material consumption and scrap throughout their long working lifetime. In typical applications, these positive environmental effects far outweigh the negative impacts of product manufacture and end-of-life disposal.

Nevertheless, when the products eventually reach the end of their useful life, they must not be discarded but should instead be recycled by a specialist recycler of electronic equipment. Recyclers will find the products easy to dismantle into their major component parts for efficient recycling. Many parts snap together and can be separated without the use of tools, while other parts are secured with conventional fasteners. Virtually all parts of the product are suitable for recycling.

Product packaging is of good quality and can be re-used. Large products are packed in wooden crates, while smaller products come in strong cardboard cartons which themselves have a high recycled fibre content. If not re-used, these containers can be recycled. Polythene, used on the protective film and bags for wrapping product, can be recycled in the same way. Control Techniques' packaging strategy prefers easily-recyclable materials of low environmental impact, and regular reviews identify opportunities for improvement.

When preparing to recycle or dispose of any product or packaging, please observe local legislation and best practice.

REACH legislation

EC Regulation 1907/2006 on the Registration, Evaluation, Authorisation and restriction of Chemicals (REACH) requires the supplier of an article to inform the recipient if it contains more than a specified proportion of any substance which is considered by the European Chemicals Agency (ECHA) to be a Substance of Very High Concern (SVHC) and is therefore listed by them as a candidate for compulsory authorisation.

For current information on how this requirement applies in relation to specific Control Techniques products, please approach your usual contact in the first instance. Control Techniques position statement can be viewed at:

<http://www.controltechniques.com/REACH>

Copyright © September 2014 Control Techniques Ltd

Issue Number: 1

Drive Firmware: 01.09.00.00 onwards

Contents

| | | |
|----------|---|-----------|
| 1 | Safety information | 5 |
| 2 | Product information | 7 |
| 2.1 | Model number | 7 |
| 2.2 | Nameplate description | 8 |
| 2.3 | Ratings | 9 |
| 2.4 | Drive features | 13 |
| 2.5 | Options / Accessories | 14 |
| 3 | Mechanical installation | 16 |
| 3.1 | Safety information | 16 |
| 3.2 | Fire protection | 16 |
| 3.3 | Mounting methods | 16 |
| 3.4 | Drive dimensions | 17 |
| 3.5 | Surface mounting | 18 |
| 3.6 | Terminal size and torque settings | 20 |
| 3.7 | Enclosure | 21 |
| 3.8 | EMC filters | 22 |
| 4 | Electrical installation | 26 |
| 4.1 | Supply types | 27 |
| 4.2 | Ratings | 27 |
| 4.3 | Power connections | 28 |
| 4.4 | Ground connections | 34 |
| 4.5 | Communications connections | 34 |
| 4.6 | Shield connections | 35 |
| 4.7 | Control connections | 35 |
| 5 | Getting started | 36 |
| 5.1 | Understanding the display | 36 |
| 5.2 | Keypad operation | 37 |
| 5.3 | Menu 0 | 40 |
| 5.4 | Menu structure | 40 |
| 5.5 | Advanced menus | 41 |
| 5.6 | Changing the operating mode | 42 |
| 5.7 | Saving parameters | 42 |
| 5.8 | Restoring parameter defaults | 43 |
| 5.9 | Displaying parameters with non-default values only | 43 |
| 5.10 | Displaying destination parameters only | 43 |
| 5.11 | Parameter access level and security | 43 |
| 6 | Basic parameters (Menu 0) | 44 |
| 6.1 | Parameter descriptions | 47 |
| 7 | Running the motor | 52 |
| 7.1 | Quick start connections | 52 |
| 7.2 | Quick Start / start-up | 57 |
| 7.3 | Quick start commissioning / start-up using Powerdrive Connect (V02.00.00.00 onwards) | 62 |
| 7.4 | Diagnostics | 65 |
| 8 | NV Media Card Operation | 67 |
| 8.1 | Introduction | 67 |
| 8.2 | NV Media Card support | 68 |
| 8.3 | Transferring data | 69 |
| 9 | Further information | 70 |
| 9.1 | Diagnostics | 70 |

| | | |
|-----------|--|-----------|
| 10 | UL listing information | 71 |
| 10.1 | General | 71 |
| 10.2 | Overload, overcurrent and overspeed protection | 71 |
| 10.3 | Short-circuit protection for branch circuits | 72 |
| 10.4 | Control circuit protection | 72 |
| 10.5 | Wiring terminal markings | 73 |
| 10.6 | Environment | 73 |
| 10.7 | Mounting | 73 |
| 10.8 | Listed accessories | 74 |
| 10.9 | cUL Marking requirements | 74 |

1 Safety information

1.1 Warnings, Cautions and Notes



A Warning contains information which is essential for avoiding a safety hazard.



A Caution contains information which is necessary for avoiding a risk of damage to the product or other equipment.

NOTE

A Note contains information, which helps to ensure correct operation of the product.

1.2 Electrical safety - general warning

The voltages used in the drive can cause severe electrical shock and/or burns, and could be lethal. Extreme care is necessary at all times when working with or adjacent to the drive. Specific warnings are given at the relevant places in this guide.

1.3 System design and safety of personnel

The drive is intended as a component for professional incorporation into complete equipment or a system. If installed incorrectly, the drive may present a safety hazard.

The drive uses high voltages and currents, carries a high level of stored electrical energy, and is used to control equipment which can cause injury.

Close attention is required to the electrical installation and the system design to avoid hazards either in normal operation or in the event of equipment malfunction. System design, installation, commissioning/start-up and maintenance must be carried out by personnel who have the necessary training and experience. They must read this safety information and this User Guide carefully.

The STOP and SAFE TORQUE OFF functions of the drive do not isolate dangerous voltages from the output of the drive or from any external option unit. The supply must be disconnected by an approved electrical isolation device before gaining access to the electrical connections.

With the sole exception of the SAFE TORQUE OFF function, none of the drive functions must be used to ensure safety of personnel, i.e. they must not be used for safety-related functions.

Careful consideration must be given to the functions of the drive which might result in a hazard, either through their intended behavior or through incorrect operation due to a fault. In any application where a malfunction of the drive or its control system could lead to or allow damage, loss or injury, a risk analysis must be carried out, and where necessary, further measures taken to reduce the risk - for example, an over-speed protection device in case of failure of the speed control, or a fail-safe mechanical brake in case of loss of motor braking.

The SAFE TORQUE OFF function may be used in a safety-related application. The system designer is responsible for ensuring that the complete system is safe and designed correctly according to the relevant safety standards.

1.4 Environmental limits

Instructions in this guide regarding transport, storage, installation and use of the drive must be complied with, including the specified environmental limits. Drives must not be subjected to excessive physical force.

1.5 Access

Drive access must be restricted to authorized personnel only. Safety regulations which apply at the place of use must be complied with.

1.6 Fire protection

The drive enclosure is not classified as a fire enclosure. A separate fire enclosure must be provided. For further information, refer to the *Drive User Guide*.

1.7 Compliance with regulations

The installer is responsible for complying with all relevant regulations, such as national wiring regulations, accident prevention regulations and electromagnetic compatibility (EMC) regulations. Particular attention must be given to the cross-sectional areas of conductors, the selection of fuses or other protection, and protective ground (earth) connections.

This guide contains instruction for achieving compliance with specific EMC standards.

Within the European Union, all machinery in which this product is used must comply with the following directives:

2006/42/EC: Safety of machinery.

2004/108/EC: Electromagnetic Compatibility.

1.8 Motor

Ensure the motor is installed in accordance with the manufacturer's recommendations. Ensure the motor shaft is not exposed.

Standard squirrel cage induction motors are designed for single speed operation. If it is intended to use the capability of the drive to run a motor at speeds above its designed maximum, it is strongly recommended that the manufacturer is consulted first.

Low speeds may cause the motor to overheat because the cooling fan becomes less effective. The motor should be installed with a protection thermistor. If necessary, an electric forced vent fan should be used.

The values of the motor parameters set in the drive affect the protection of the motor. The default values in the drive should not be relied upon.

It is essential that the correct value is entered in Pr **00.046** motor rated current. This affects the thermal protection of the motor.

1.9 Adjusting parameters

Some parameters have a profound effect on the operation of the drive. They must not be altered without careful consideration of the impact on the controlled system. Measures must be taken to prevent unwanted changes due to error or tampering.

1.10 Electrical installation

1.10.1 Electric shock risk

The voltages present in the following locations can cause severe electric shock and may be lethal:

- AC supply cables and connections
- Output cables and connections
- Many internal parts of the drive, and external option units

Unless otherwise indicated, control terminals are single insulated and must not be touched.

1.10.2 Stored charge

The drive contains capacitors that remain charged to a potentially lethal voltage after the AC supply has been disconnected. If the drive has been energized, the AC supply must be isolated at least ten minutes before work may continue.

2 Product information

This guide covers the *Powerdrive F300* product.

Table 2-1 Supported operating modes

| Product | Supported operating modes | | |
|-----------------|---------------------------|------------------|------------------|
| | Open-Loop | RFC-A Sensorless | RFC-S Sensorless |
| Powerdrive F300 | ✓ | ✓ | ✓ |

2.1 Model number

The way in which the model numbers for the *Powerdrive F300* product range is formed is illustrated below:

Figure 2-1 Model number

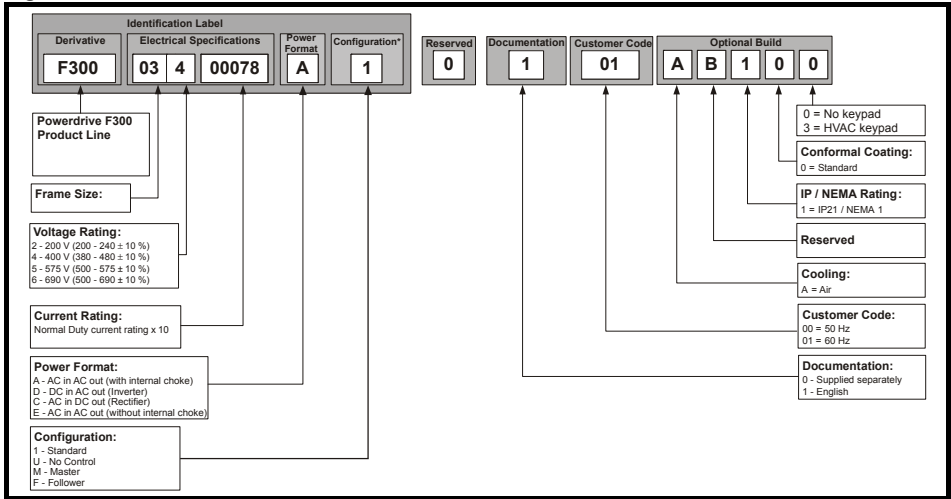

* Only shown on frame size 9E and 10 identification label.

NOTE

For simplicity a Frame 9 drive with no internal choke (i.e. Model 09xxxxxxE) is referred to as a Frame 9E and a Frame 9 drive with an internal choke (i.e. Model 09xxxxxxA) is referred to as a Frame 9A. Any reference to Frame 9 is applicable to both sizes 9E and 9A.

2.2 Nameplate description

Figure 2-2 Typical drive rating labels

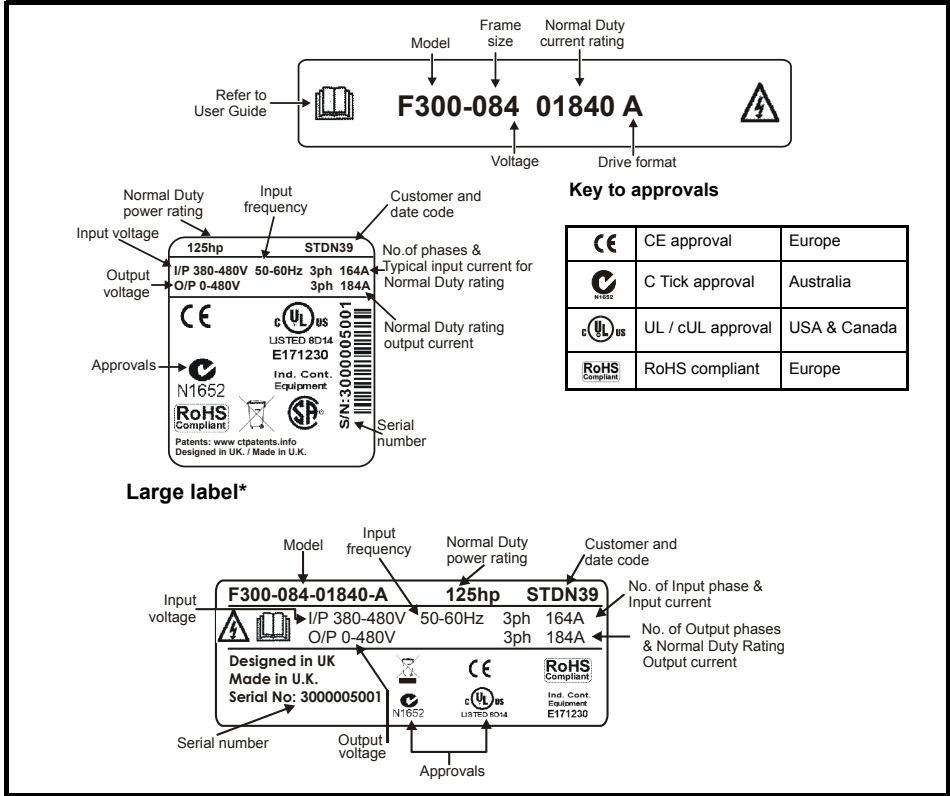

* This label is only applicable to size 7 and above.

Refer to Figure 2-1 *Model number* on page 7 for further information relating to the labels.

2.3 Ratings



Fuses

The AC supply to the drive must be installed with suitable protection against overload and short-circuits. The following section shows recommended fuse ratings. Failure to observe this requirement will cause risk of fire.

NOTE

Nominal cables sizes below are based on the cable installation method B2 (ref: IEC60364-5-52:2001) unless otherwise specified, and are provided as a guide only. Ensure cables used suit local wiring regulations.

Table 2-2 200 V drive ratings, cable sizes and fuse ratings

| Model | Max. cont. input current | Fuse | | | | Nominal cable size | | | | Normal Duty | | | |
|----------|--------------------------|------|-----|-------|-------------|--------------------|--------------|---------|---------|---------------------------|-------------------|---------------------|--------|
| | | IEC | | UL | | European | | USA | | Max. cont. output current | Nom power @ 230 V | Motor power @ 230 V | |
| | | 3ph | Nom | Class | Nom | Class | Input | Output | Input | | | | Output |
| | | | | | | | | | | | | | |
| 03200066 | 10.7 | 16 | | 16 | | 1.5 | 1.5 | 14 | 14 | 6.6 | 1.1 | 1.5 | |
| 03200080 | 13 | 20 | gG | 20 | CC, J or T* | 1.5 | 1.5 | 14 | 14 | 8 | 1.5 | 2 | |
| 03200110 | 17.8 | 25 | | 25 | | 4 | 4 | 12 | 12 | 11 | 2.2 | 3 | |
| 03200127 | 20.6 | 25 | | 25 | | 4 | 4 | 12 | 12 | 12.7 | 3 | 3 | |
| 04200180 | 20.1 | 25 | gG | 25 | CC, J or T* | 6 | 6 | 10 | 10 | 18 | 4 | 5 | |
| 04200250 | 26.8 | 32 | | 30 | | 8 | 8 | 8 | 8 | 25 | 5.5 | 7.5 | |
| 05200300 | 31 | 40 | gG | 40 | CC, J or T* | 10 | 10 | 8 | 8 | 30 | 7.5 | 10 | |
| 06200500 | 48.8 | 63 | gG | 60 | CC, J or T* | 16 | 16 | 4 | 4 | 50 | 11 | 15 | |
| 06200580 | 56.6 | 63 | | 70 | | 25 | 25 | 3 | 3 | 58 | 15 | 20 | |
| 07200750 | 67 | 80 | gG | 80 | CC, J or T* | 35 | 35 | 2 | 2 | 75 | 18.5 | 25 | |
| 07200940 | 84 | 100 | | 100 | | 35 | 35 | 1 | 1 | 94 | 22 | 30 | |
| 07201170 | 105 | 125 | | 125 | | 70 | 70 | 1/0 | 1/0 | 117 | 30 | 40 | |
| 08201490 | 137 | 200 | gR | 200 | HSJ | 95 | 95 | 3/0 | 3/0 | 149 | 37 | 50 | |
| 08201800 | 166 | 200 | | 225 | | 2 x 70 | 2 x 70 | 2 x 1 | 2 x 1 | 180 | 45 | 60 | |
| 09202160 | 205 | 250 | gR | 250 | HSJ | 2 x 70 (B1) | 2 x 95 (B2) | 2 x 2/0 | | 216 | 55 | 75 | |
| 09202660 | 260 | 315 | | 300 | | 2 x 95 (B1) | 2 x 120 (B2) | 2 x 4/0 | | 266 | 75 | 100 | |
| 10203250 | 278 | 400 | gR | 400 | HSJ | 2 x 120 (B1) | 2 x 120 (B2) | 2 x 250 | | 325 | 90 | 125 | |
| 10203600 | 333 | 450 | | 450 | | 2 x 150 (C) | | 2 x 300 | 2 x 250 | 360 | 110 | 150 | |

Safety information

Product information

Mechanical installation

Electrical installation

Getting started

Basic parameters (Menu 0)

Running the motor

NV Media Card Operation

Further information

UL listing information

Table 2-3 400 V drive ratings, cable sizes and fuse ratings

| Model | Max. cont. input current | Fuse | | | | Nominal cable size | | | | Normal Duty | | | |
|----------|--------------------------|------|-----|-------|-------------|--------------------|--------------|---------|---------|---------------------------|-------------------|---------------------|--------|
| | | IEC | | UL | | European | | USA | | Max. cont. output current | Nom power @ 400 V | Motor power @ 460 V | |
| | | 3ph | Nom | Class | Nom | Class | Input | Output | Input | | | | Output |
| | | | | | | | | | | | | | |
| 03400034 | 5 | 6 | gG | 10 | CC, J or T* | 1.5 | 1.5 | 18 | 18 | 3.4 | 1.1 | 1.5 | |
| 03400045 | 6.6 | 10 | | 10 | | 1.5 | 1.5 | 16 | 16 | 4.5 | 1.5 | 2 | |
| 03400062 | 9.1 | 10 | | 10 | | 1.5 | 1.5 | 14 | 14 | 6.2 | 2.2 | 3 | |
| 03400077 | 13.1 | 20 | | 20 | | 2.5 | 2.5 | 14 | 14 | 7.7 | 3 | 5 | |
| 03400104 | 13.4 | 20 | | 20 | | 2.5 | 2.5 | 14 | 14 | 10.4 | 4 | 5 | |
| 03400123 | 15.8 | 20 | | 20 | | 2.5 | 2.5 | 12 | 12 | 12.3 | 5.5 | 7.5 | |
| 04400185 | 18.7 | 25 | gG | 25 | CC, J or T* | 4 | 4 | 10 | 10 | 18.5 | 7.5 | 10 | |
| 04400240 | 24.3 | 32 | | 30 | | 6 | 6 | 8 | 8 | 24 | 11 | 15 | |
| 05400300 | 29 | 40 | gG | 35 | CC, J or T* | 6 | 6 | 8 | 8 | 30 | 15 | 20 | |
| 05400310 | | 40 | | 35 | | 6 | 6 | 8 | 8 | 31 | | | |
| 06400380 | 36 | 63 | gR | 40 | HSJ or DFJ | 10 | 10 | 6 | 6 | 38 | 18.5 | 25 | |
| 06400480 | 46 | 63 | | 50 | | 16 | 16 | 4 | 4 | 48 | 22 | 30 | |
| 06400630 | 80 | 63 | | 70 | | 25 | 25 | 3 | 3 | 63 | 30 | 40 | |
| 07400790 | 74 | 100 | gG | 80 | CC, J or T* | 35 | 35 | 1 | 1 | 79 | 37 | 50 | |
| 07400940 | 88 | 100 | | 100 | | 50 | 50 | 2 | 2 | 94 | 45 | 60 | |
| 07401120 | 105 | 125 | | 125 | | 70 | 70 | 1/0 | 1/0 | 112 | 55 | 75 | |
| 08401550 | 155 | 250 | gR | 225 | HSJ | 2 x 50 | 2 x 50 | 2 x 1 | 2 x 1 | 155 | 75 | 100 | |
| 08401840 | 177 | 250 | | 225 | | 2 x 70 | 2 x 70 | 2 x 1/0 | 2 x 1/0 | 184 | 90 | 125 | |
| 09402210 | 232 | 315 | gR | 300 | HSJ | 2 x 70 (B1) | 2 x 95 (B2) | 2 x 3/0 | 2 x 2/0 | 221 | 110 | 150 | |
| 09402660 | 267 | | | 350 | | 2 x 95 (B1) | 2 x 120 (B2) | 2 x 4/0 | 2 x 4/0 | 266 | 132 | 200 | |
| 10403200 | 332 | 400 | gR | 400 | HSJ | 2 x 120 (C) | 2 x 120 (B2) | 2 x 300 | 2 x 250 | 320 | 160 | 250 | |
| 10403610 | 397 | 450 | | 450 | | 2 x 150 (C) | 2 x 150 (B2) | 2 x 350 | 2 x 300 | 361 | 200 | 300 | |

Table 2-4 575 V drive ratings, cable sizes and fuse ratings

| Model | Max. cont. input current | Fuse | | | | Nominal cable size | | | | Normal Duty | | | |
|----------|--------------------------|------|-----|-------|-------------|--------------------|-------------|---------|---------|---------------------------|-------------------|---------------------|--------|
| | | IEC | | UL | | European | | USA | | Max. cont. output current | Nom power @ 575 V | Motor power @ 575 V | |
| | | 3ph | Nom | Class | Nom | Class | Input | Output | Input | | | | Output |
| | | | | | | | | | | | | | |
| 05500039 | 4.3 | 10 | gG | 10 | CC, J or T* | 0.75 | 0.75 | 16 | 16 | 3.9 | 2.2 | 3 | |
| 05500061 | 5.7 | 10 | | 10 | | 1 | 1 | 14 | 14 | 6.1 | 4 | 5 | |
| 05500100 | 9.3 | 20 | | 20 | | 1.5 | 1.5 | 14 | 14 | 10 | 5.5 | 7.5 | |
| 06500120 | 13.2 | 20 | gG | 20 | CC, J or T* | 2.5 | 2.5 | 14 | 14 | 12 | 7.5 | 10 | |
| 06500170 | 18.7 | 32 | | 25 | | 4 | 4 | 10 | 10 | 17 | 11 | 15 | |
| 06500220 | 24.3 | 40 | | 30 | | 6 | 6 | 10 | 10 | 22 | 15 | 20 | |
| 06500270 | 29.4 | 50 | | 35 | | 10 | 10 | 8 | 8 | 27 | 18.5 | 25 | |
| 06500340 | 37.1 | 50 | | 40 | | 10 | 10 | 6 | 6 | 34 | 22 | 30 | |
| 06500430 | 46.9 | 63 | | 50 | | 16 | 16 | 6 | 6 | 43 | 30 | 40 | |
| 07500530 | 45 | 50 | gG | 50 | CC, J or T* | 16 | 16 | 4 | 4 | 53 | 37 | 50 | |
| 07500730 | 62 | 80 | | 80 | | 25 | 25 | 3 | 3 | 73 | 45 | 60 | |
| 08500860 | 83 | 125 | gR | 100 | HSJ | 35 | 35 | 1 | 1 | 86 | 55 | 75 | |
| 08501080 | 104 | 160 | | 150 | | 50 | 50 | 1 | 1 | 108 | 75 | 100 | |
| 09501250 | 166 | 150 | gR | 150 | HSJ | 2 x 70 (B2) | 2 x 35 (B2) | 2 x 1 | 2 x 3 | 125 | 90 | 125 | |
| 09501500 | | 200 | | 175 | | | 2 x 50 (B2) | | 2 x 1 | 150 | 110 | 150 | |
| 10502000 | 197 | 250 | gR | 250 | HSJ | 2 x 70 (B2) | 2 x 70 (B2) | 2 x 2/0 | 2 x 2/0 | 200 | 130 | 200 | |

Table 2-5 690 V drive ratings, cable sizes and fuse ratings

| Model | Max. cont. input current | Fuse | | | | Nominal cable size | | | | Normal Duty | | | |
|----------|--------------------------|------|-----|-------|-------------|--------------------|-------------|-------------|---------|---------------------------|-------------------|---------------------|--------|
| | | IEC | | UL | | European | | USA | | Max. cont. output current | Nom power @ 690 V | Motor power @ 690 V | |
| | | 3ph | Nom | Class | Nom | Class | Input | Output | Input | | | | Output |
| | | | | | | | | | | | | | |
| 07600230 | 20 | 25 | gG | 25 | CC, J or T* | 10 | 10 | 8 | 8 | 23 | 18.5 | 25 | |
| 07600300 | 26 | 32 | | 30 | | 10 | 10 | 6 | 6 | 30 | 22 | 30 | |
| 07600360 | 31 | 40 | | 35 | | 10 | 10 | 6 | 6 | 36 | 30 | 40 | |
| 07600460 | 39 | 50 | | 50 | | 16 | 16 | 4 | 4 | 46 | 37 | 50 | |
| 07600520 | 44 | 50 | | 50 | | 16 | 16 | 4 | 4 | 52 | 45 | 60 | |
| 07600730 | 62 | 80 | | 80 | | 25 | 25 | 3 | 3 | 73 | 55 | 75 | |
| 08600860 | 83 | 125 | gR | 100 | HSJ | 50 | 50 | 2 | 2 | 86 | 75 | 100 | |
| 08601080 | 104 | 160 | | 150 | | 70 | 70 | 1/0 | 1/0 | 108 | 90 | 125 | |
| 09601250 | 149 | 150 | gR | 150 | HSJ | 2 x 50 (B2) | 2 x 35 (B2) | 2 x 1 | 2 x 3 | 125 | 110 | 150 | |
| 09601500 | 171 | 200 | | 200 | | 2 x 70 (B2) | 2 x 50 (B2) | 2 x 1/0 | 2 x 1 | 155 | 132 | 175 | |
| 10601720 | 202 | 225 | gR | 250 | HSJ | 2 x 70 (B2) | 2 x 70 (B2) | 2 x 2/0 | 2 x 1/0 | 172 | 160 | 200 | |
| 10601970 | 225 | 250 | | | | aR | | 2 x 95 (B2) | 2 x 3/0 | 2 x 2/0 | 197 | 185 | 250 |

* These fuses are fast acting.

Table 2.3 Protective ground cable ratings

| Input phase conductor size | Minimum ground conductor size |
|---|---|
| ≤ 10 mm ² | Either 10 mm ² or two conductors of the same cross-sectional area as the input phase conductor (an additional ground connection is provided on sizes 3, 4 and 5 for this purpose). |
| > 10 mm ² and ≤ 16 mm ² | The same cross-sectional area as the input phase conductor |
| > 16 mm ² and ≤ 35 mm ² | 16 mm ² |
| > 35 mm ² | Half of the cross-sectional area of the input phase conductor |

Typical short term overload limits

The maximum percentage overload limit changes depending on the selected motor. Variations in motor rated current, motor power factor and motor leakage inductance all result in changes in the maximum possible overload. Typical values are shown in the table below:

Table 2-6 Typical overload limits

| Operating mode | RFC from cold | RFC from 100 % | Open loop from cold | Open loop from 100 % |
|---|-----------------|----------------|---------------------|----------------------|
| Normal Duty overload with motor rated current = drive rated current | 110 % for 165 s | 110 % for 9 s | 110 % for 165 s | 110 % for 9 s |

Generally the drive rated current is higher than the matching motor rated current allowing a higher level of overload than the default setting.

The time allowed in the overload region is proportionally reduced at very low output frequency on some drive ratings.

NOTE The maximum overload level which can be attained is independent of the speed.

Output current

The continuous output current ratings given on the rating label are for maximum 40 °C (104 °F), 1000 m altitude and 3.0 kHz switching frequency. Derating is required for higher switching frequencies, ambient temperatures >40 °C (104 °F) and higher altitude. For derating information,

refer to the *Drive User Guide*.

Input current

The input current is affected by the supply voltage and impedance. The input current given on the rating label is the typical input current and is stated for a balanced supply.

Input line reactor (Frame 9E and 10)

A line reactor must be used with Frame 9E and 10. Failure to provide sufficient reactance could damage or reduce the service life of the drive. Refer to Table 2-7 below.

Table 2-7 Size 9E and 10 model and line reactor part numbers

| Size | Drive model | Inductor model | Line reactor part number |
|------|--|----------------|--------------------------|
| 9 | 09202160, 09202660, 09402210, 09402660 | INL 401 | 4401-0181 |
| | | INL 401W* | 4401-0208 |
| | 09501250, 09501500, 09601250, 09601500 | INL 601 | 4401-0183 |
| 10 | 10293250, 10203600, 10403200, 10403610 | INL 402 | 4401-0182 |
| | | INL 402W* | 4401-0209 |
| | 10502000, 10601720, 10601970 | INL 602 | 4401-0184 |

* This may represent a more economical solution where operating temperature and cooling requirements are observed. Refer to the *Drive User Guide* for further information.

2.4 Drive features

Figure 2-4 Features of the drive (size 3 to 10)

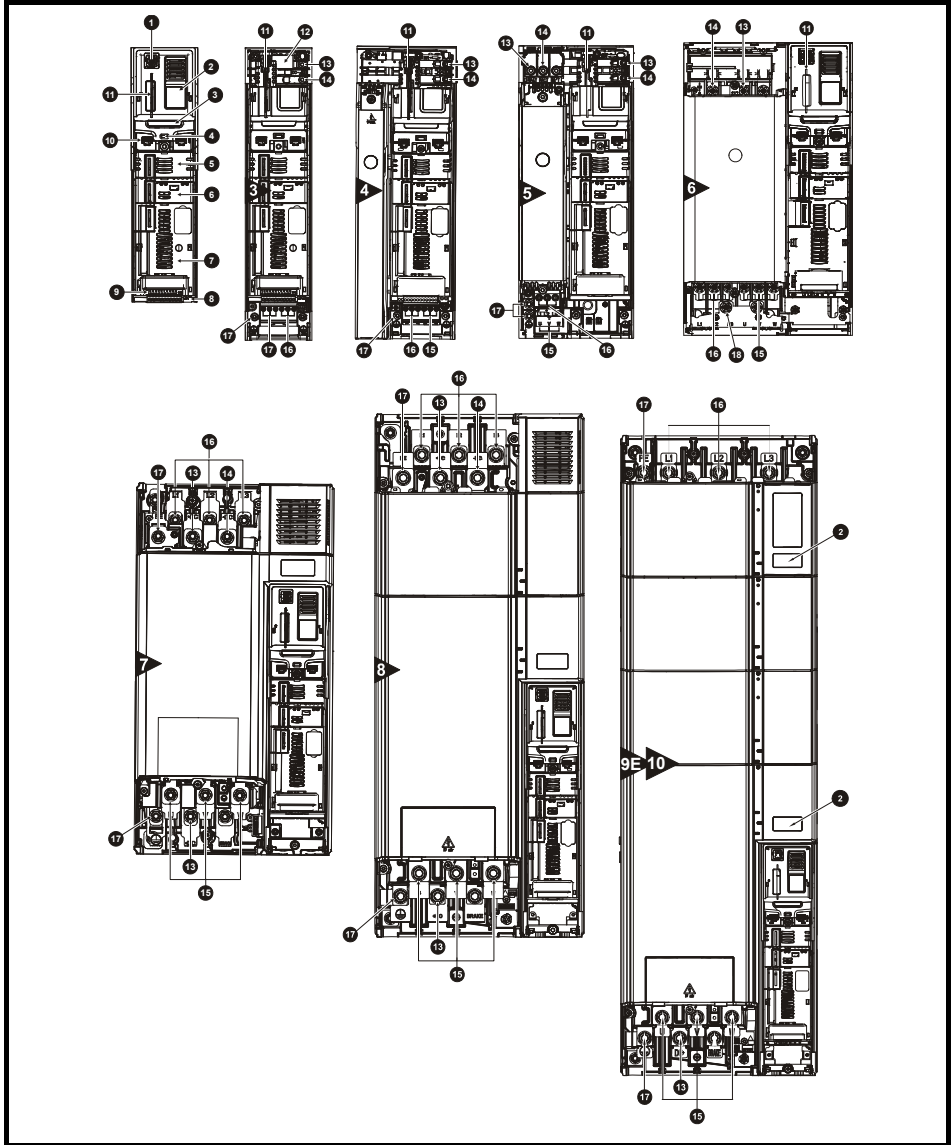

Key

- | | | | |
|-------------------------|-------------------------|-------------------------|---------------------------|
| 1. Keypad connection | 6. Option module slot 2 | 11. NV media card slot | 16. AC supply connections |
| 2. Rating label | 7. Option module slot 3 | 12. Internal EMC filter | 17. Ground connections |
| 3. Identification label | 8. Relay connections | 13. DC bus + | |
| 4. Status LED | 9. Control connections | 14. DC bus - | |
| 5. Option module slot 1 | 10. Communications port | 15. Motor connections | |

2.5 Options / Accessories

Figure 2-5 Drive features and options

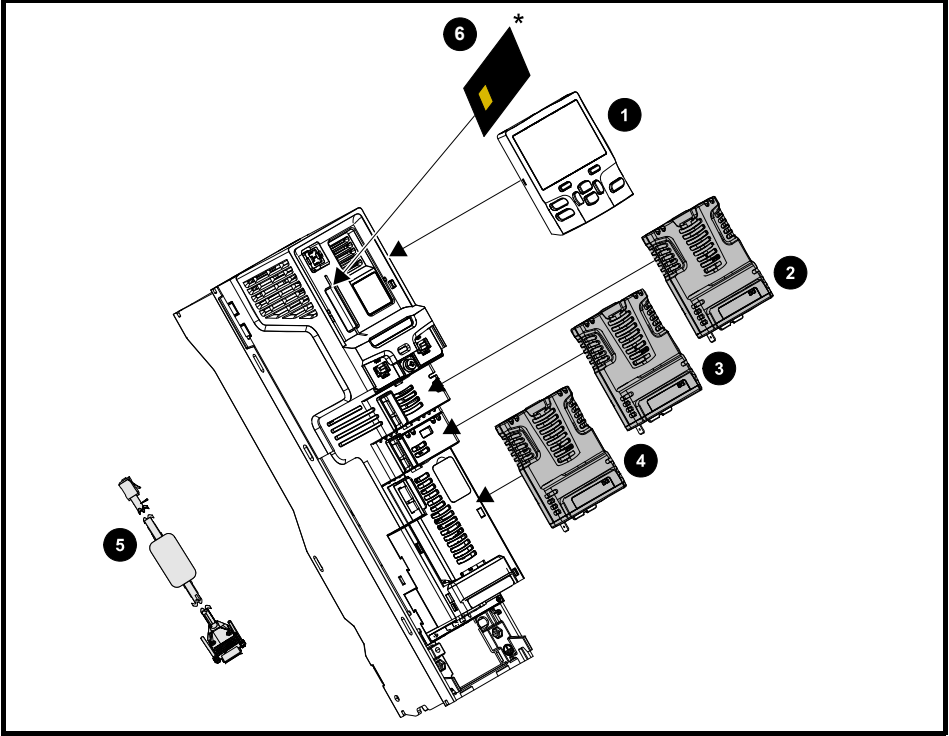

1. Keypad

2. Option module slot 1

3. Option module slot 2

4. Option module slot 3

5. CT Comms cable

6. NV media card

Table 2-8 Option modules, Keypad and additional options available

| Type | Name | Further details |
|----------------------------|-------------------|---|
| Fieldbus | KI-485 Adaptor | 485 Comms Adaptor 485 Comms adaptor provides 485 communication interface. This adaptor supports 115 k Baud, node addresses between 1 to 16 and 8 1 NP M serial mode. |
| | SI-PROFIBUS | Profibus option PROFIBUS adapter for communications with the drive. |
| | SI-DeviceNet | DeviceNet option DeviceNet adapter for communications with the drive. |
| | SI-CANopen | CANopen option CANopen adapter for communications with the drive. |
| | SI-Ethernet | Ethernet option External Ethernet module that supports EtherNet/IP and Modbus TCP/IP |
| | SI-PROFINET RT | PROFINET RT option PROFINET adapter for communications with the drive. |
| Automation (I/O expansion) | SI-I/O | Extended I/O Increases the I/O capability by adding the following combinations: Digital I/O, Digital Inputs, Analog Inputs (differential or single ended), Analog Output, Relays. |
| Keypad | KI-HOA Keypad RTC | LCD keypad option Keypad with a LCD display and real time clock. |
| Back-up | SD Card Adaptor | SD Card Adaptor Allows the drive to use an SD card for drive back-up. |
| | SMARTCARD | SMARTCARD Used for parameter back-up with the drive. |

For more information refer to the *Drive User Guide* and the relevant option module user guide.

2.5.1 Parts supplied with the drive

Items such as control terminals, relay connector, 24 V power supply connector, grounding bracket, surface mount brackets, grounding clamp, DC terminal cover grommets, terminal nuts, supply and motor connector and finger guard grommets are provided with the drive. For more information refer to the label on the accessory kit box supplied with the drive.

| |
|---------------------------|
| Safety information |
| Product Information |
| Mechanical installation |
| Electrical installation |
| Getting started |
| Basic parameters (Menu 0) |
| Running the motor |
| NV Media Card Operation |
| Further information |
| UL listing information |

3 Mechanical installation

3.1 Safety information



Follow the instructions

The mechanical and electrical installation instructions must be adhered to. Any questions or doubt should be referred to the supplier of the equipment. It is the responsibility of the owner or user to ensure that the installation of the drive and any external option unit, and the way in which they are operated and maintained, comply with the requirements of the Health and Safety at Work Act in the United Kingdom or applicable legislation and regulations and codes of practice in the country in which the equipment is used.



Stored charge

The drive contains capacitors that remain charged to a potentially lethal voltage after the AC supply has been disconnected. If the drive has been energized, the AC supply must be isolated at least ten minutes before work may continue.

Normally, the capacitors are discharged by an internal resistor. Under certain, unusual fault conditions, it is possible that the capacitors may fail to discharge, or be prevented from being discharged by a voltage applied to the output terminals. If the drive has failed in a manner that causes the display to go blank immediately, it is possible the capacitors will not be discharged. In this case, consult Control Techniques or their authorized distributor.



Competence of the installer

The drive must be installed by professional assemblers who are familiar with the requirements for safety and EMC. The assembler is responsible for ensuring that the end product or system complies with all the relevant laws in the country where it is to be used.



Enclosure

The drive is intended to be mounted in an enclosure which prevents access except by trained and authorized personnel, and which prevents the ingress of contamination. It is designed for use in an environment classified as pollution degree 2 in accordance with IEC 60664-1. This means that only dry, non-conducting contamination is acceptable.

3.2 Fire protection

The drive enclosure is not classified as a fire enclosure. A separate fire enclosure must be provided.

For installation in the USA, a NEMA 12 enclosure is suitable.

For installation outside the USA, refer to the *Drive User Guide*.

3.3 Mounting methods

All drive sizes can be either surface or through-panel mounted using the appropriate brackets.



If the drive has been used at high load levels for a period of time, the heatsink can reach temperatures in excess of 70 °C (158 °F). Human contact with the heatsink should be prevented.

3.4 Drive dimensions

Figure 3-1 Drive dimensions

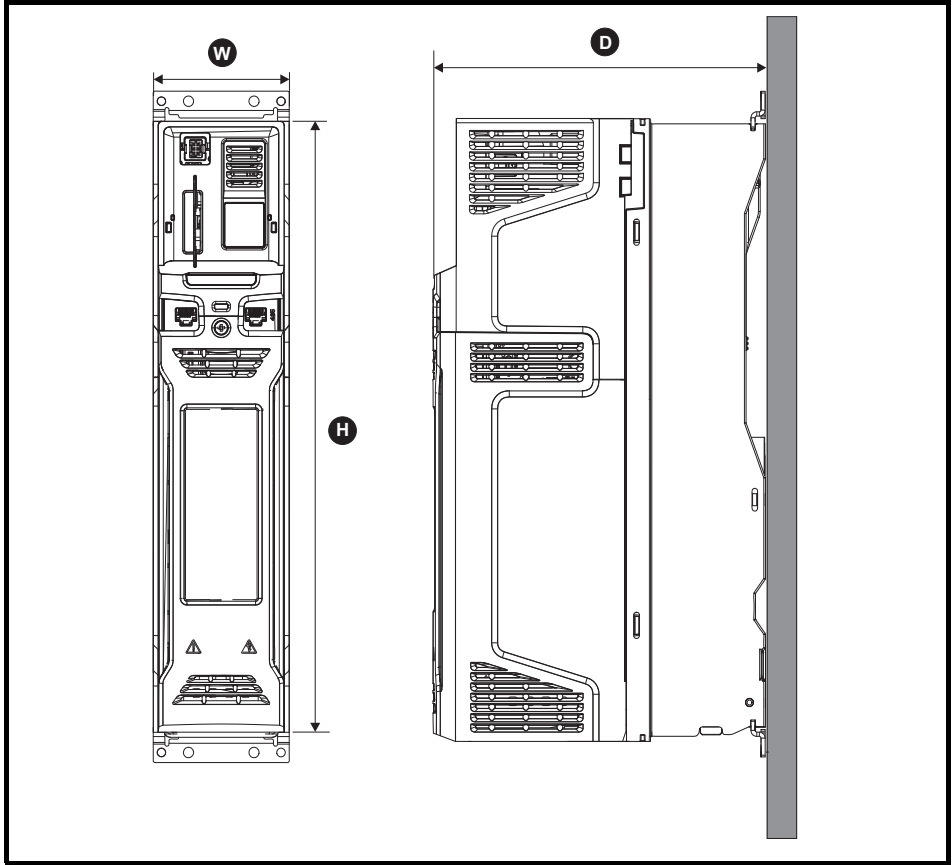

| Size | H | | W | | D | |
|-----------|------|-------|-----|-------|-----|-------|
| | mm | in | mm | in | mm | in |
| 3 | 365 | 14.37 | 83 | 3.27 | 200 | 7.87 |
| 4 | | | 124 | 4.88 | | |
| 5 | | | 143 | 5.63 | | |
| 6 | | | 210 | 8.27 | | |
| 7 | 508 | 20 | 270 | 10.63 | 279 | 11 |
| 8 | 753 | 29.65 | 310 | 12.21 | 290 | 11.42 |
| 9E and 10 | 1069 | 42.09 | 310 | 12.21 | 289 | 11.38 |

3.5 Surface mounting

Figure 3-2 Surface mounting dimensions (size 3 to 7)

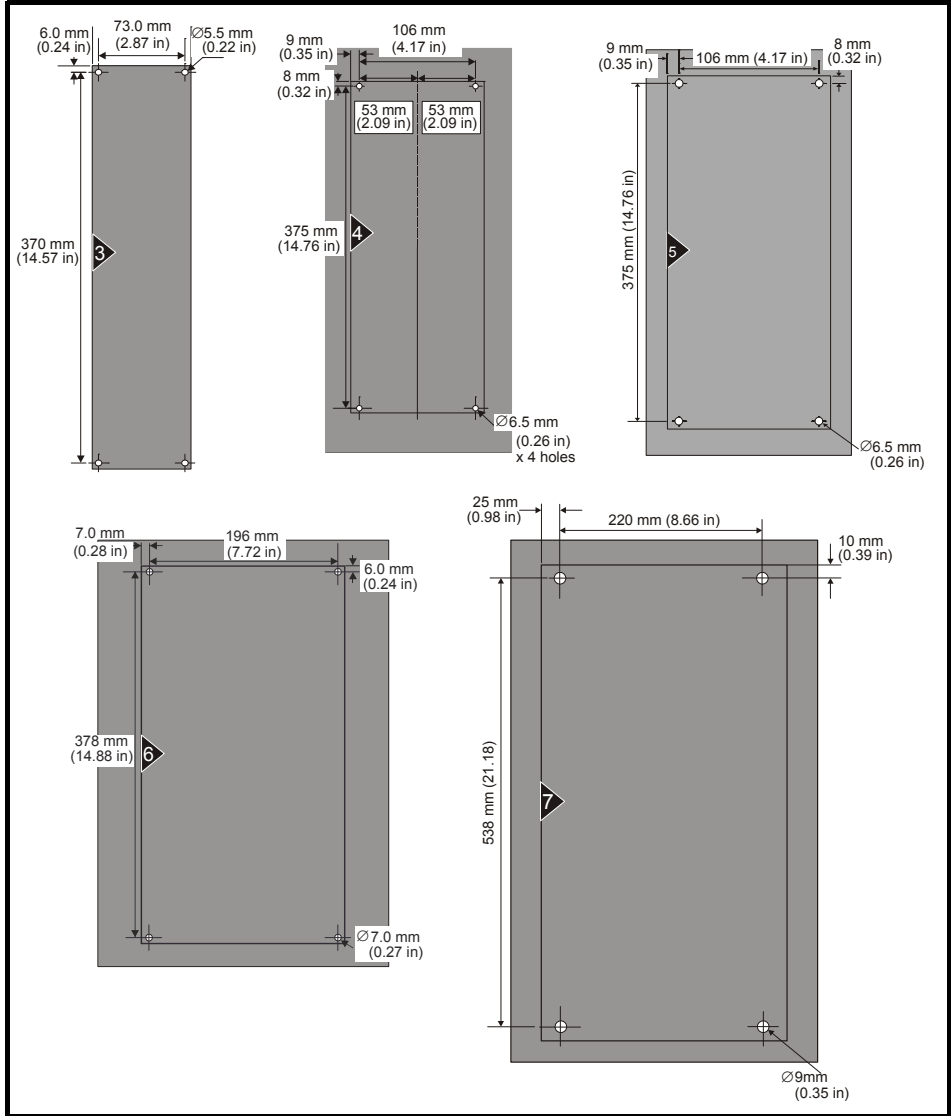
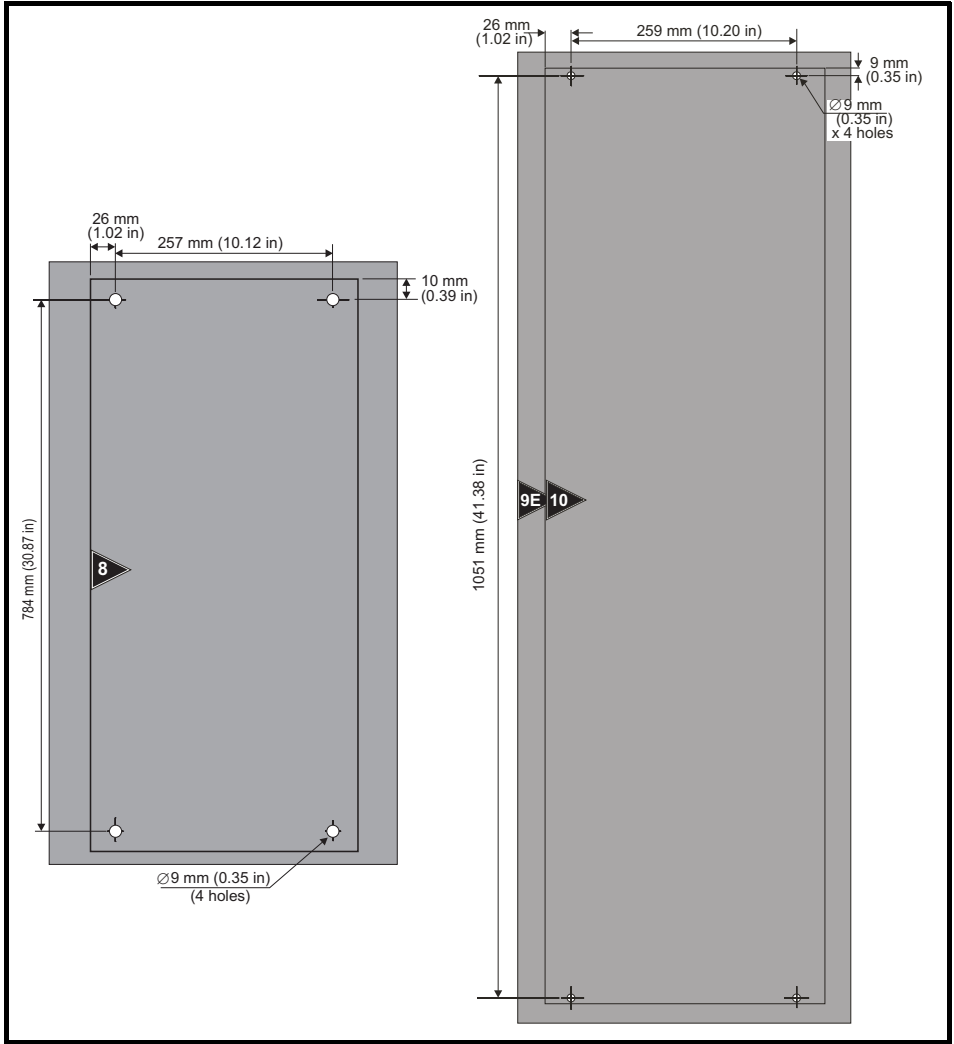

Figure 3-3 Surface mounting dimensions (size 8 to 10)



| |
|--------------------------------|
| Safety information |
| Product information |
| Mechanical installation |
| Electrical installation |
| Getting started |
| Basic parameters (Menu 0) |
| Running the motor |
| NV Media Card Operation |
| Further information |
| UL listing information |

3.6 Terminal size and torque settings

Table 3-1 Drive control and relay terminal data

| Model | Connection type | Torque setting |
|-------|------------------------|---------------------|
| All | Plug-in terminal block | 0.5 N m (0.4 lb ft) |

Table 3-2 Drive power terminal data

| Model size | AC terminals | DC terminals | Ground terminal |
|------------|---|-------------------------------------|-------------------------------------|
| | Recommended | | |
| 3 and 4 | Plug-in terminal block | T20 Torx (M4) | T20 Torx (M4) / M4 Nut (7 mm AF) |
| | 0.7 N m (0.5 lb ft) | 2.0 N m (1.47 lb ft) | 2.0 N m (1.47 lb ft) |
| 5 | Plug-in terminal block 1.8 N m (1.3 lb ft) | T20 Torx (M4) / M4 Nut (7 mm AF) | M5 Nut (8 mm AF) |
| | 1.5 N m (1.1 lb ft) | 1.5 N m (1.1 lb ft) | 2.0 N m (1.47 lb ft) |
| 6 | | M6 Nut (10 mm AF) | |
| | | 6.0 N m (4.42 lb ft) | |
| 7 | | M8 Nut (13 mm AF) | |
| | | 12.0 N m (8.85 lb ft) | |
| 8 to 10 | | M10 Nut (17 mm AF) | |
| | | 15.0 N m (11.1 lb ft) | |

3.8 EMC filters

3.8.1 Internal filter

It is recommended that the internal EMC filter be kept in place unless there is a specific reason for removing it. If the drive is part of a regen system or it is connected to an IT supply then the internal EMC filter must be removed. The internal EMC filter reduces radio-frequency emission into the line power supply. Where the motor cable is short, it permits the requirements of EN 61800-3:2004 to be met for the second environment - for further information see the *Drive User Guide*. For longer motor cables the filter continues to provide a useful reduction in emission level, and when used with any length of shielded motor cable up to the limit for the drive, it is unlikely that nearby industrial equipment will be disturbed. It is recommended that the filter be used in all applications unless the instructions given above require it to be removed or the ground leakage current of the drive is unacceptable.

Figure 3-5 Removal of Size 3 internal EMC filter

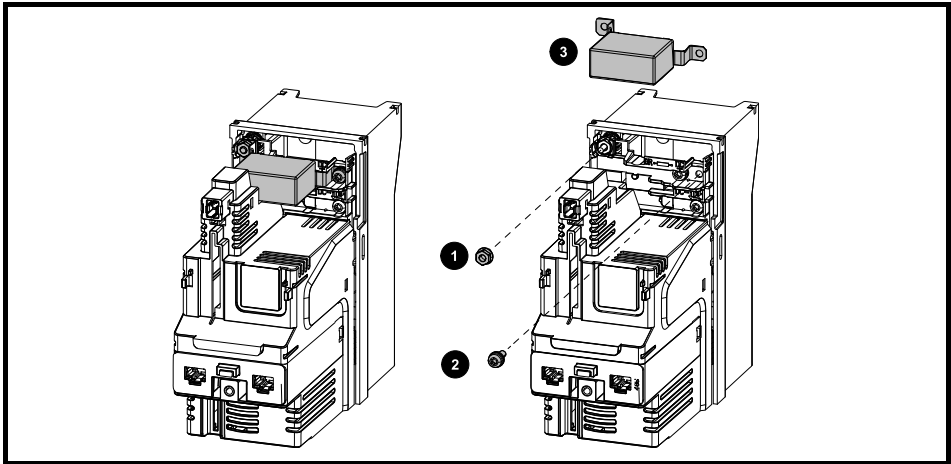

Loosen / remove the screw and nut as shown (1) and (2).

Lift away from securing points and then rotate away from the drive. Ensure the screw and nut are replaced and re-tightened with a maximum torque of 2 N m (1.47 lb ft).

Figure 3-6 Removal of the size 4 internal EMC filter

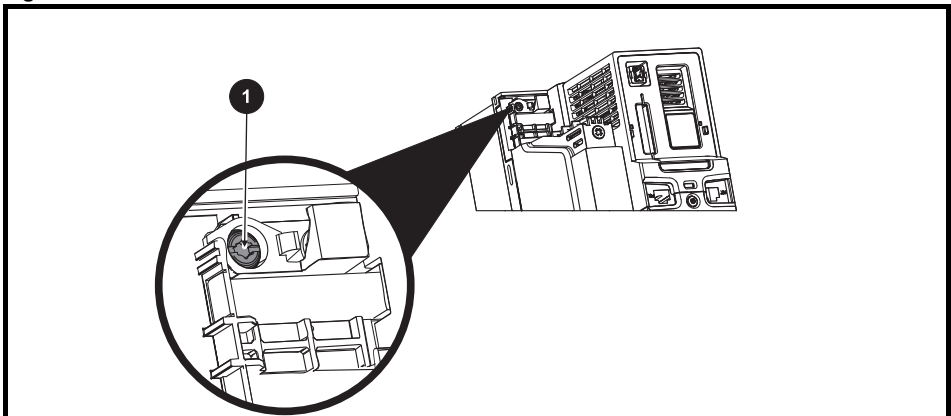

To electrically disconnect the Internal EMC filter, remove the screw (1) as highlighted above.

Figure 3-7 Removal of the size 5 internal EMC filter

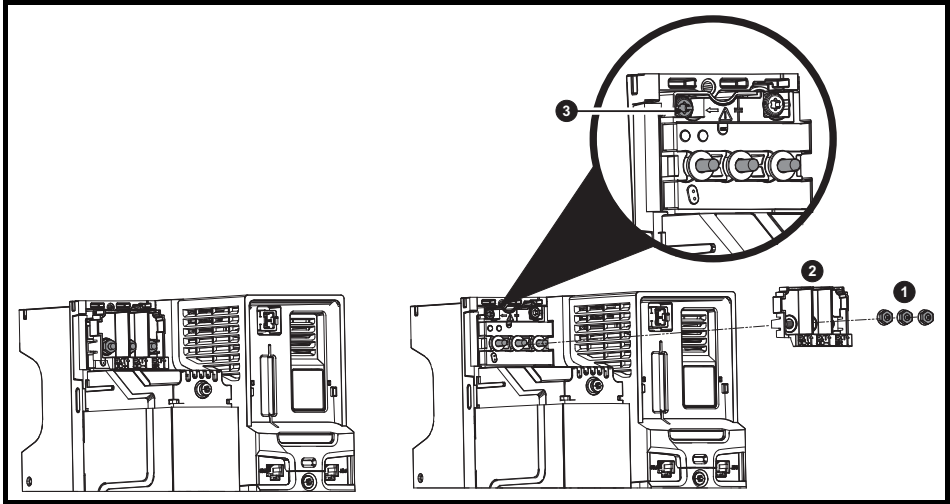

Remove the three M5 terminal nuts (1). Lift away the cover (2) to expose the M4 Torx internal EMC filter removal screw. Finally remove the M4 Torx internal EMC filter removal screw (3) to electrically disconnect the internal EMC filter.

Figure 3-8 Removal of the size 6 internal EMC filter

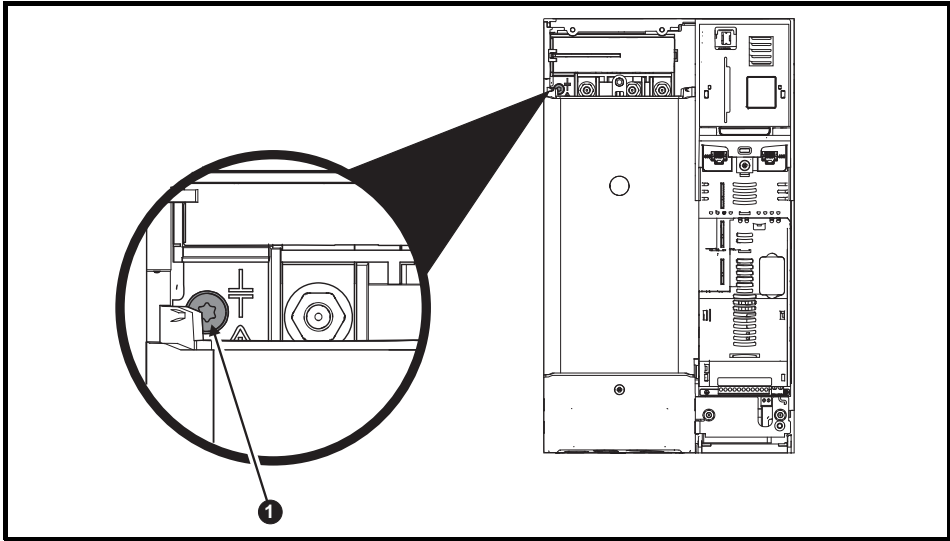

To electrically disconnect the Internal EMC filter, remove the screw (1) as highlighted above.

Figure 3-9 Removal of the size 7 and 8 internal EMC filter and line to ground varistors (size 7 shown)

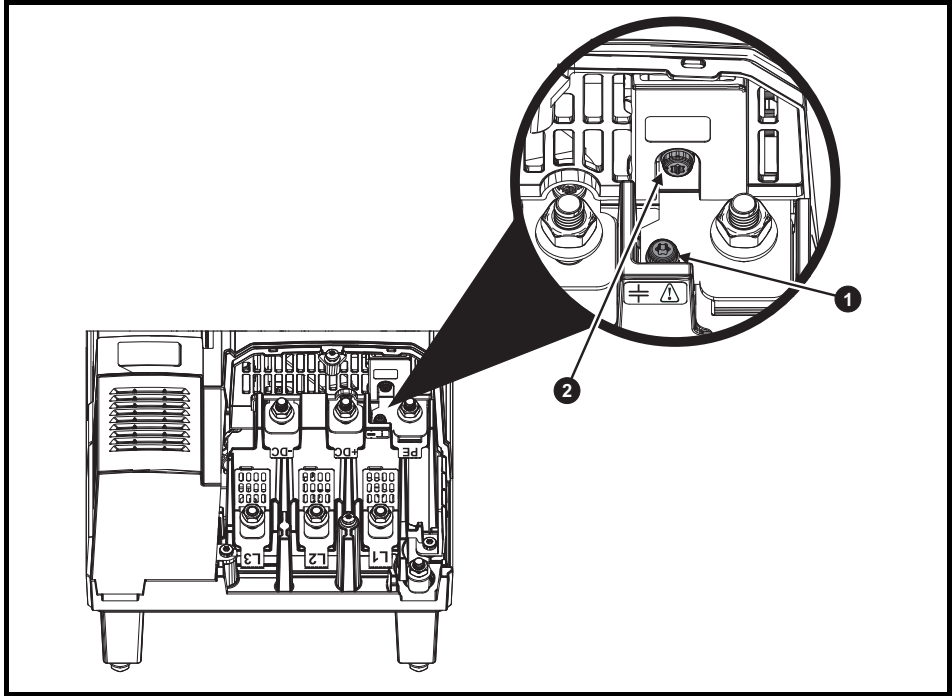

To electrically disconnect the Internal EMC filter, remove the screw as highlighted above (1).

To electrically disconnect the line to ground varistors, remove the screw as highlighted above (2).

NOTE

The line to ground varistors should only be removed in special circumstances such as ungrounded supplies with more than one source, for example on ships. Contact the supplier of the drive for more information.

Figure 3-10 Removal of size 9E and 10 line to ground varistors

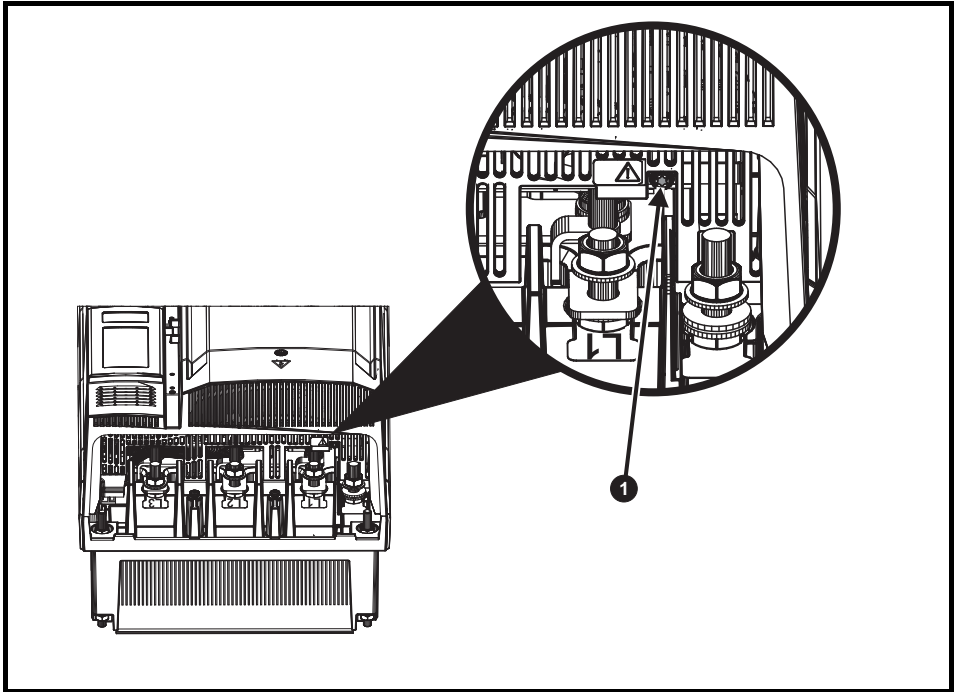

To electrically disconnect the line to ground varistors, remove the screw as highlighted above (1).

NOTE

The Internal EMC filter on size 9E and 10 cannot be removed.

NOTE

The line to ground varistors should only be removed in special circumstances such as ungrounded supplies with more than one source, for example on ships. Contact the supplier of the drive for more information.

3.8.2 External filter

The external EMC filter for size 3, 4, 5 and 6 can be footprint or bookcase mounted.

For information on drive and EMC filter cross reference, refer to the *Drive User Guide*.



To avoid a fire hazard and maintain validity of the UL listing, adhere to the specified tightening torques for the power and ground terminals.

For further information refer to the *Drive User Guide*.

4 Electrical installation



Electric shock risk

The voltages present in the following locations can cause severe electric shock and may be lethal:

AC supply cables and connections

DC cables and connections

Output cables and connections

Many internal parts of the drive, and external option units

Unless otherwise indicated, control terminals are single insulated and must not be touched.



Isolation device

The AC and / or DC power supply must be disconnected from the drive using an approved isolation device before any cover is removed from the drive or before any servicing work is performed.



STOP function

The STOP function does not remove dangerous voltages from the drive, the motor or any external option units.



SAFE TORQUE OFF function

The SAFE TORQUE OFF function does not remove dangerous voltages from the drive, the motor or any external option units.



Stored charge

The drive contains capacitors that remain charged to a potentially lethal voltage after the AC and / or DC power supply has been disconnected. If the drive has been energized, the AC and / or DC power supply must be isolated at least ten minutes before work may continue. Normally, the capacitors are discharged by an internal resistor. Under certain, unusual fault conditions, it is possible that the capacitors may fail to discharge, or be prevented from being discharged by a voltage applied to the output terminals. If the drive has failed in a manner that causes the display to go blank immediately, it is possible the capacitors will not be discharged. In this case, consult Control Techniques or their authorized distributor.



Equipment supplied by plug and socket

Special attention must be given if the drive is installed in equipment which is connected to the AC supply by a plug and socket. The AC supply terminals of the drive are connected to the internal capacitors through rectifier diodes which are not intended to give safety isolation. If the plug terminals can be touched when the plug is disconnected from the socket, a means of automatically isolating the plug from the drive must be used (e.g. a latching relay).



Permanent magnet motors

Permanent magnet motors generate electrical power if they are rotated, even when the supply to the drive is disconnected. If that happens then the drive will become energized through its motor terminals. If the motor load is capable of rotating the motor when the supply is disconnected, then the motor must be isolated from the drive before gaining access to any live parts.

4.1 Supply types

All drives are suitable for use on any supply type i.e TN-S, TN-C-S, TT and IT.

Supplies with voltage up to 600 V may have grounding at any potential, i.e. neutral, centre or corner ("grounded delta")

Supplies with voltage above 600 V may not have corner grounding

Drives are suitable for use on supplies of installation category III and lower, according to IEC 60664-1. This means they may be connected permanently to the supply at its origin in a building, but for outdoor installation additional over-voltage suppression (transient voltage surge suppression) must be provided to reduce category IV to category III.

NOTE If the drive is to be used on an IT (ungrounded) supply, refer to the *Drive User Guide* for more information.

4.2 Ratings

See section 2.3 *Ratings* on page 9.

Maximum continuous input current

The values of maximum continuous input current are given to aid the selection of cables and fuses. These values are stated for the worst case condition with the unusual combination of stiff supply with high imbalance. The value stated for the maximum continuous input current would only be seen in one of the input phases. The current in the other two phases would be significantly lower.

The values of maximum input current are stated for a supply with a 2 % negative phase-sequence imbalance and rated at the maximum supply fault current given in section 2.3 *Ratings* on page 9.

The nominal cable sizes given in section 2.3 *Ratings* on page 9 are only a guide. Refer to local wiring regulations for the correct size of cables. In some cases a larger cable is required to avoid excessive voltage drop.

NOTE The nominal output cable sizes in section 2.3 *Ratings* on page 9 assume that the motor maximum current matches that of the drive. Where a motor of reduced rating is used the cable rating may be chosen to match that of the motor. To ensure that the motor and cable are protected against over-load, the drive must be programmed with the correct motor rated current.



Fuses

The AC supply to the drive must be installed with suitable protection against overload and short-circuits. Nominal fuse ratings are shown in section 2.3 *Ratings* on page 9. Failure to observe this requirement will cause risk of fire.

A fuse or other protection must be included in all live connections to the AC supply. An MCB (miniature circuit breaker) or MCCB (moulded-case circuit-breaker) with type C may be used in place of fuses for size 3 under the following conditions:

- The fault-clearing capacity must be sufficient for the installation.

Fuse types

The fuse voltage rating must be suitable for the drive supply voltage.

4.3 Power connections

Figure 4-1 Size 3 power and ground connections

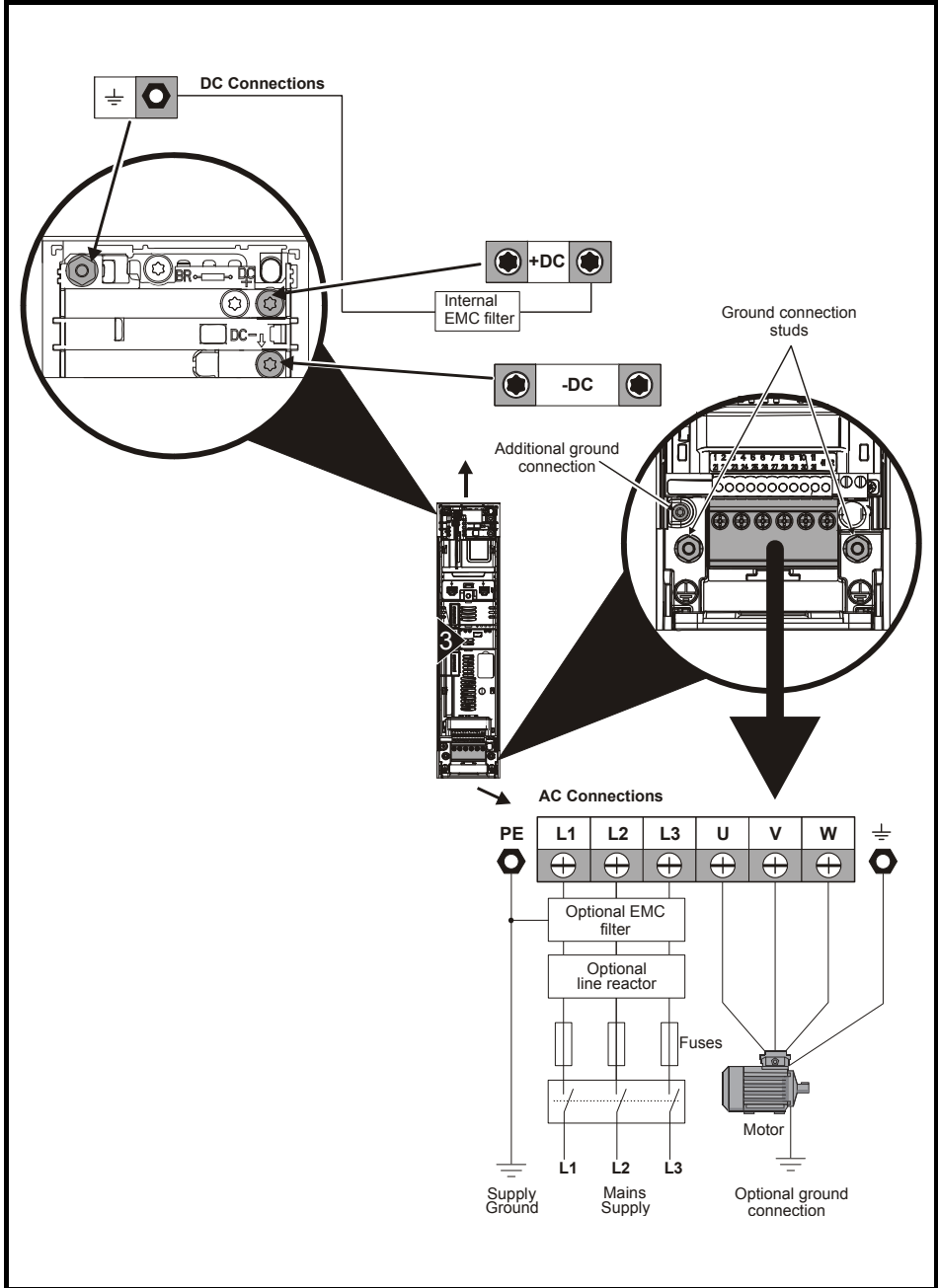
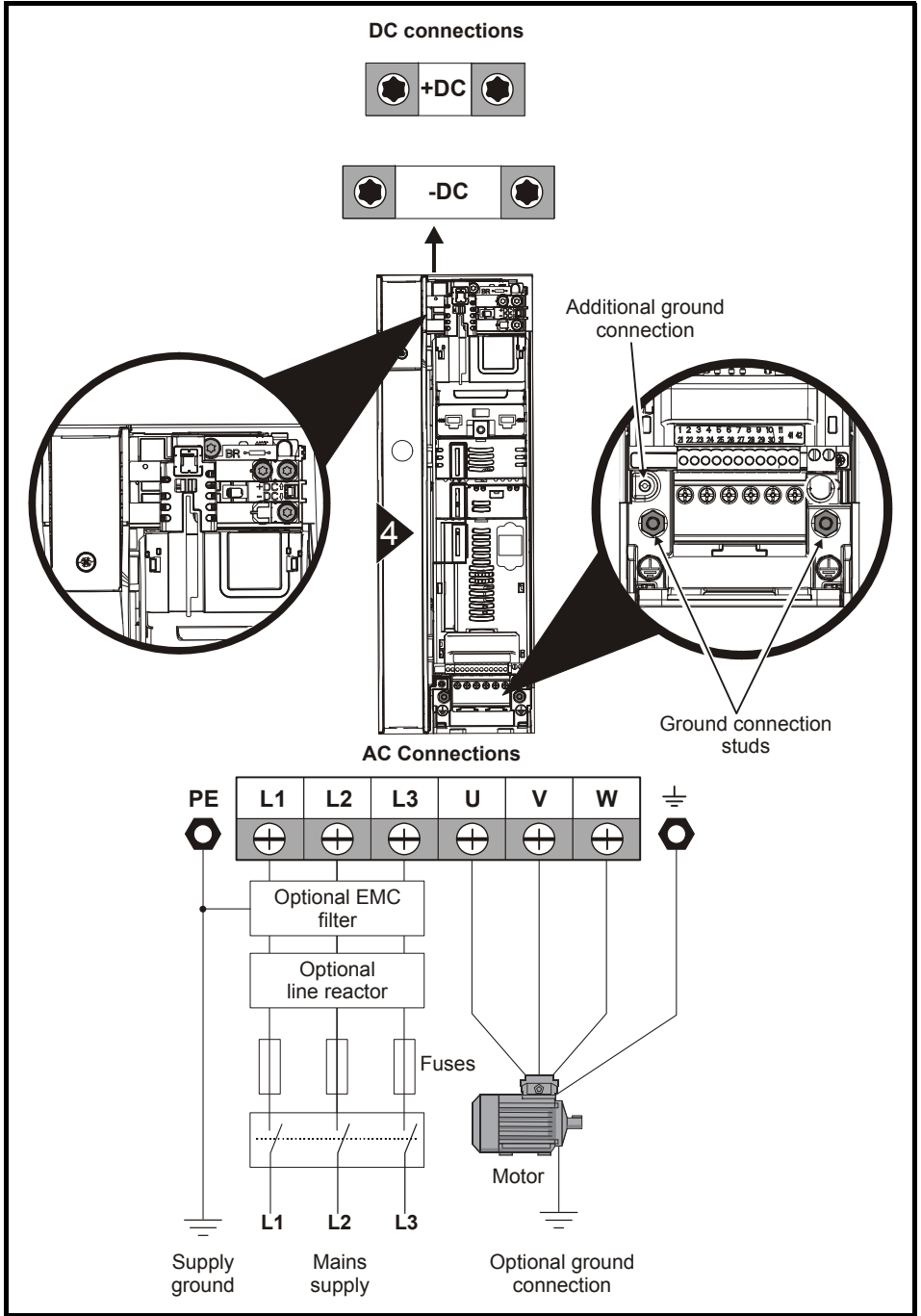
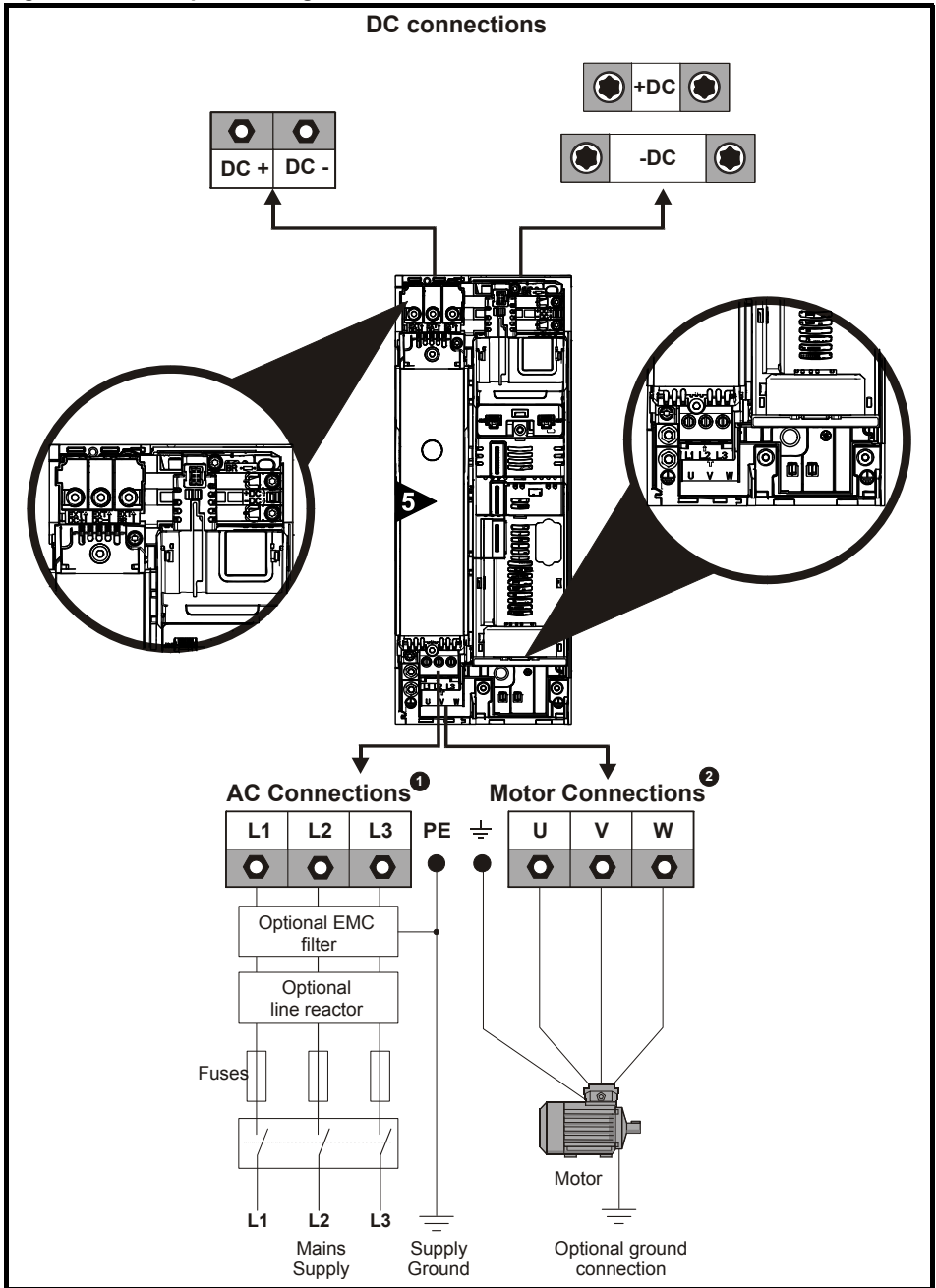

Figure 4-2 Size 4 power and ground connections



| |
|--------------------------------|
| Safety information |
| Product information |
| Mechanical installation |
| Electrical installation |
| Getting started |
| Basic parameters (Menu 0) |
| Running the motor |
| NV Media Card Operation |
| Further information |
| UL listing information |

Figure 4-3 Size 5 power and ground connections



The upper terminal block (1) is used for AC supply connection.

The lower terminal block (2) is used for Motor connection.

Figure 4-4 Size 6 power and ground connections

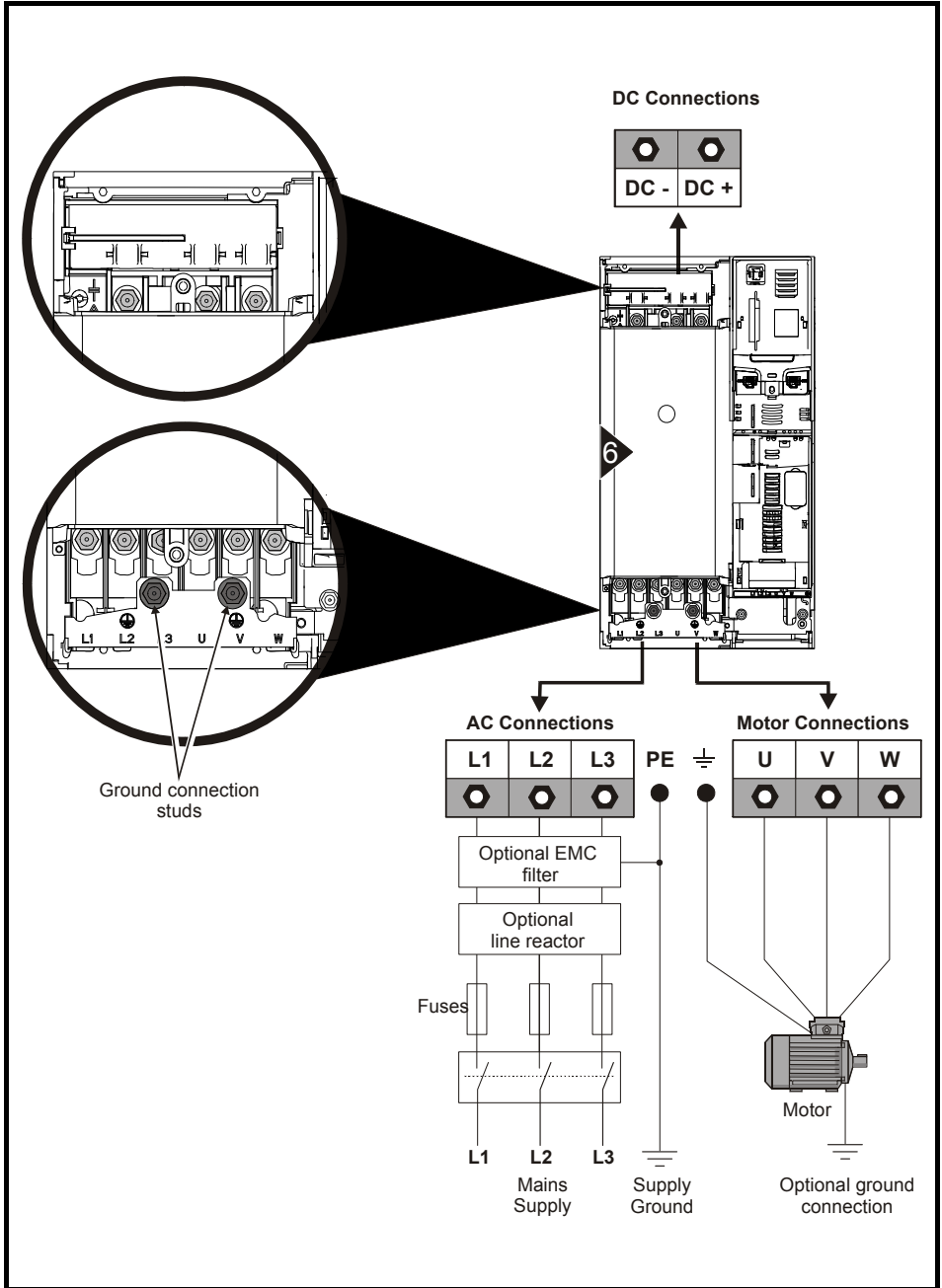

Safety information

Product information

Mechanical installation

Electrical installation

Getting started

Basic parameters (Menu 0)

Running the motor

NV Media Card Operation

Further information

UL listing information

Figure 4-5 Size 7 and 8 power and ground connections (size 7 shown)

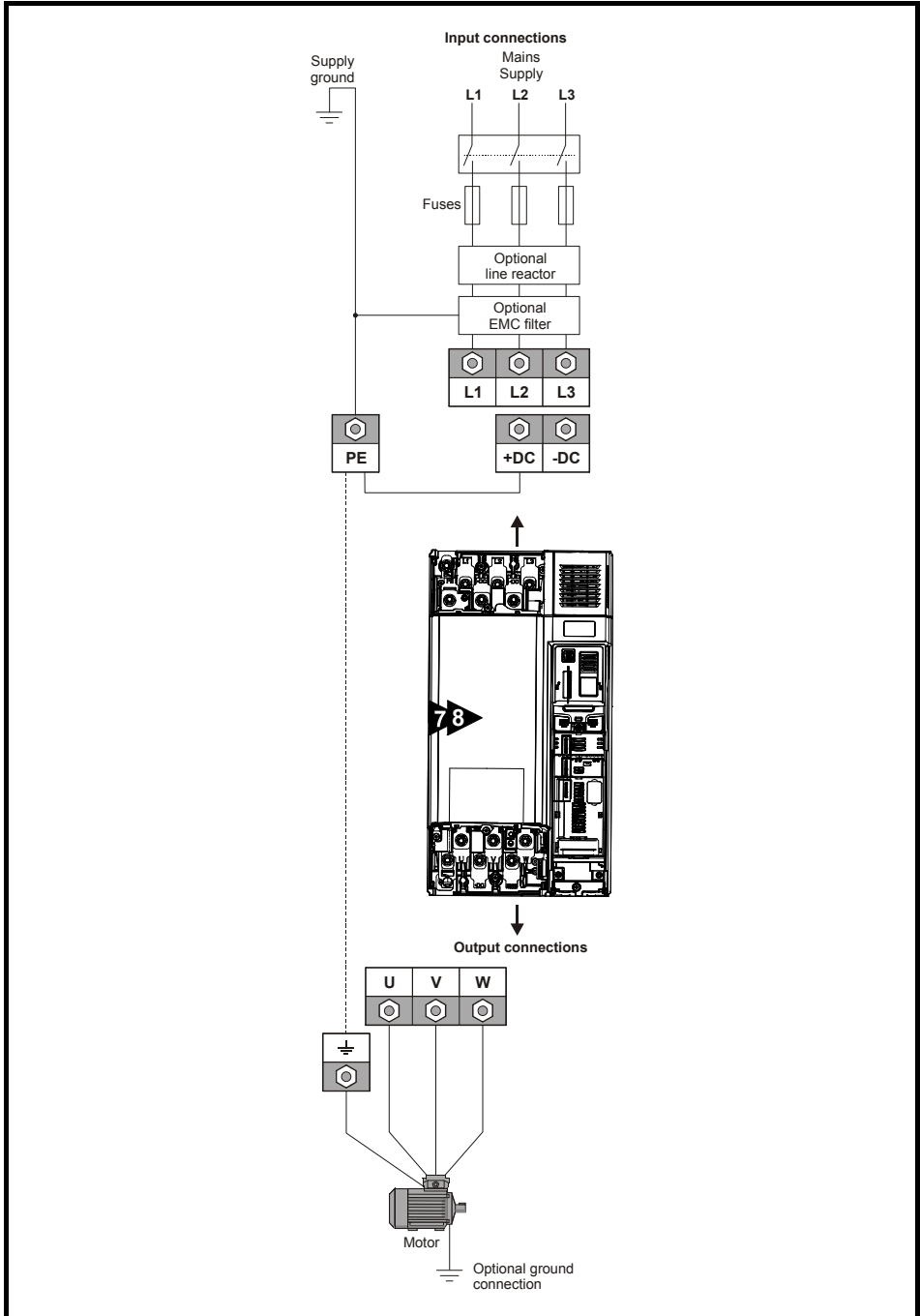
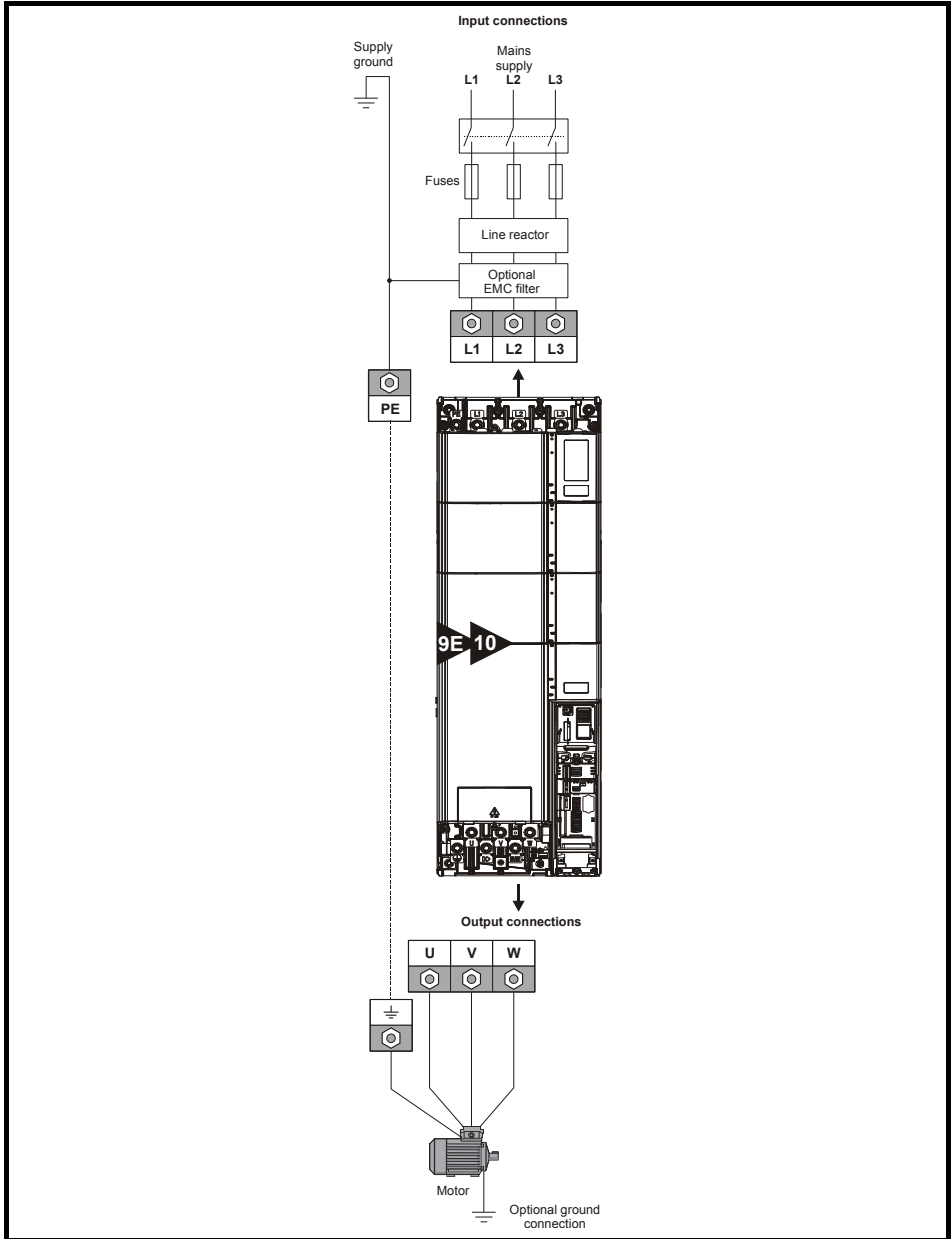

Figure 4-6 Size 9E and 10 power and ground connections



A separate line reactor (INLXXX) must be used for size 9E and 10. Failure to provide sufficient reactance could damage or reduce the service life of the drive. Refer to Table 2-7 *Size 9E and 10 model and line reactor part numbers* on page 12.

| |
|--------------------------------|
| Safety information |
| Product information |
| Mechanical installation |
| Electrical installation |
| Getting started |
| Basic parameters (Menu 0) |
| Running the motor |
| NV/ Media Card Operation |
| Further information |
| UL listing information |

4.4 Ground connections



Electrochemical corrosion of grounding terminals

Ensure that grounding terminals are protected against corrosion i.e. as could be caused by condensation.

The drive must be connected to the system ground of the AC supply. The ground wiring must conform to local regulations and codes of practice.

NOTE

For further information on ground cable sizes, refer to Table * *These fuses are fast acting.* on page 11.

On size 3 and 4, the supply and motor ground connections are made using the M4 studs located either side of the drive near the plug-in power connectors. See Figure 4-1 and Figure 4-2 for details.

On size 5, the supply and motor ground connections are made using the M5 studs located near the plug-in power connector. Refer to Figure 4-3.

On a size 6, the supply and motor ground connections are made using the M6 studs located above the supply and motor terminals. Refer to Figure 4-4.

On size 7, the supply and motor ground connections are made using the M8 studs located by the supply and motor connection terminals. Refer to Figure 4-5.

On size 8, the supply and motor ground connections are made using the M10 studs located by the supply and motor connection terminals. Refer to Figure 4-5.

On size 9E and 10, the supply and motor ground connections are made using the M10 studs located by the supply and motor connection terminals. Refer to Figure 4-6.



The ground loop impedance must conform to the requirements of local safety regulations.

The drive must be grounded by a connection capable of carrying the prospective fault current until the protective device (fuse, etc.) disconnects the AC supply.

The ground connections must be inspected and tested at appropriate intervals.

4.5 Communications connections

The drive offers a 2 wire 485 serial interface. This enables the drive set-up, operation and monitoring to be carried out with a PC or controller if required. The drive provides two parallel RJ45 connectors allowing easy daisy chaining. The drive supports the Modbus RTU protocol. See Table 4-1 for the connection details.

Table 4-1 Serial communication port pin-outs

| Pin | Function |
|-------|--|
| 1 | 120 Ω Termination resistor |
| 2 | RX TX |
| 3 | Isolated 0 V |
| 4 | +24 V (100 mA) |
| 5 | Isolated 0 V |
| 6 | TX enable |
| 7 | RX\ TX\ |
| 8 | RX\ TX\ (if termination resistors are required, link to pin 1) |
| Shell | Isolated 0 V |

4.6 Shield connections

The following guidelines should be followed to ensure suppression of radio-frequency emission and good noise immunity. Use the grounding bracket and grounding clamp supplied with the drive to terminate the shields at the drive.

Figure 4-7 Grounding of signal cable shields using the grounding bracket

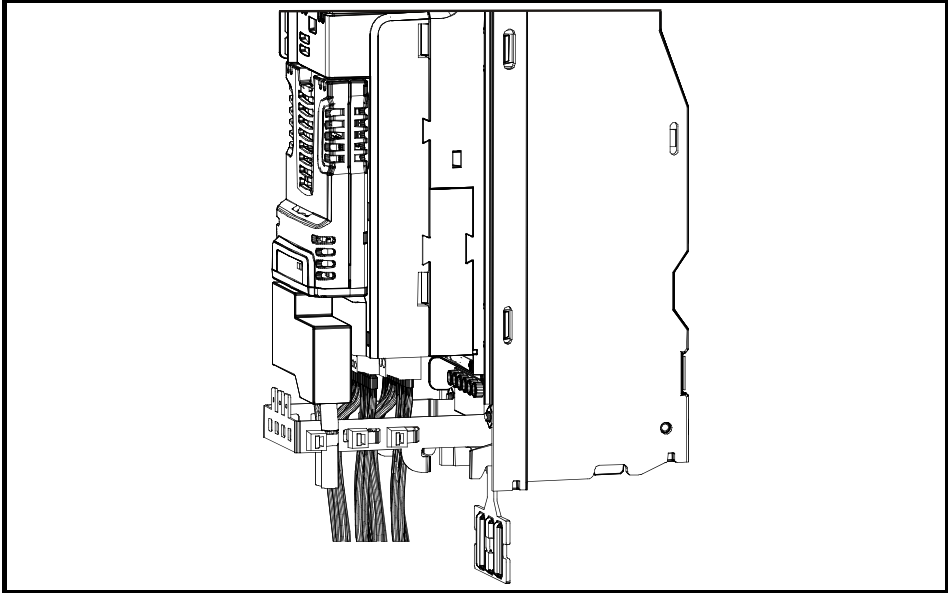

Motor cable: Use a motor cable with an overall shield. Connect the shield of the motor cable to the ground terminal of the motor frame using a link that is as short as possible and not exceeding 50 mm (2 in) long. A full 360 ° termination of the shield to the terminal housing of the motor is beneficial.

Control cables: If the control wiring is to leave the enclosure, it must be shielded and the shield(s) clamped to the drive using the grounding bracket. Remove the outer insulating cover of the cable to ensure the shield(s) make contact with the bracket, but keep the shield(s) intact until as close as possible to the terminals.

4.7 Control connections

For information on control connections, refer to the back cover of this guide.

5 Getting started

This chapter introduces the user interfaces, menu structure and security level of the drive.

5.1 Understanding the display

The keypad can only be mounted on the drive.

5.1.1 KI-HOA Keypad RTC

The KI-HOA Keypad RTC display consists of two rows of text. The upper row shows the drive status or the menu and parameter number currently being viewed. The lower row of the display line shows the parameter value or the specific trip type. The last two characters on the first row may display special indications. If more than one of these indications is active then the indications are prioritized as shown in Table 5-1

When the drive is powered up the lower row will show the power up parameter defined by *Parameter Displayed At Power-up* (11.022).

Figure 5-1 KI-HOA Keypad RTC

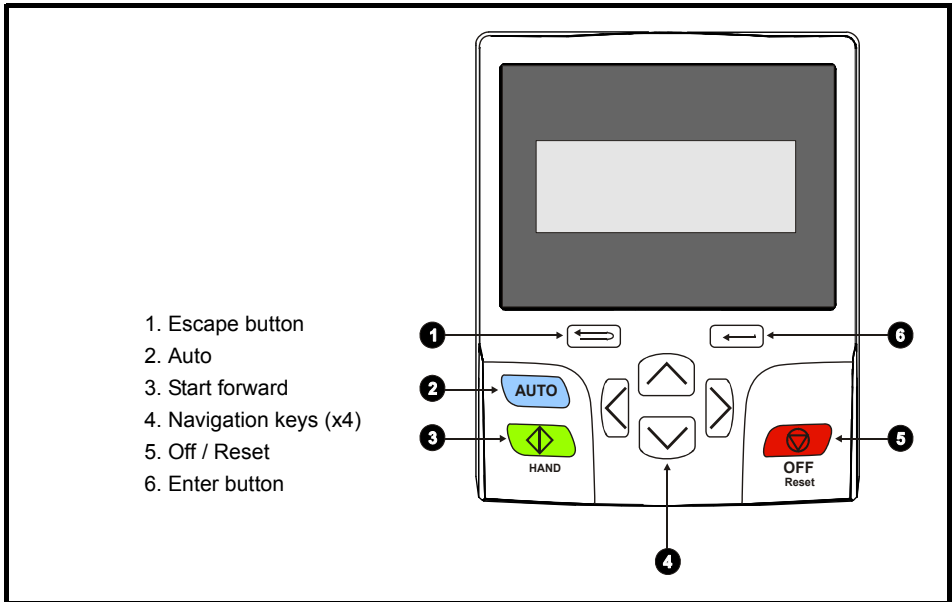

NOTE









The red  button is also used to reset the drive.

Table 5-1 Active action icon

| Active action icon | Description | Row (1=top) | Priority in row |
|--|--|-------------|-----------------|
|  | Accessing non-volatile media card | 1 | 1 |
|  | Alarm active | 1 | 2 |
|  | Keypad real-time clock battery low | 1 | 3 |
|  or  | Drive security active and locked or unlocked | 1 | 4 |
|  | User program running | 3 | 1 |
|  | Keypad reference active | 4 | 1 |

5.2 Keypad operation

5.2.1 Control buttons

The keypad consists of:



- Navigation Keys - Used to navigate the parameter structure and change parameter values.
- Enter / Mode button - Used to toggle between parameter edit and view mode.
- Escape / Exit button - Used to exit from parameter edit or view mode. In parameter edit mode, if parameter values are edited and the exit button pressed the parameter value will be restored to the value it had on entry to edit mode.
- Three control buttons - used to select Hand / Off / Auto modes (see section 5.2.2 below).

5.2.2 Hand / Off / Auto

Hand / Off / Auto functions are enabled if Pr **01.052** is set to a non-zero value, otherwise the keypad buttons are allocated as follows:

- Blue  - Forward/Reverse
- Green  - Run
- Red  - Reset

When Hand / Off / Auto functions are enabled (Pr **01.052** set to either 1, 2 or 3), then the keypad buttons will be allocated as follows:

- Blue  - Auto
- Green  - Hand
- Red  - Off/Reset

The value in Pr **01.052** selects Hand/Off/Auto mode on power-up as shown in Table 5-2.

Table 5-2 Hand/Off/Auto mode

| Pr 01.052 | Power up |
|------------------|------------------------|
| 0 | Hand/Off/Auto disabled |
| 1 | Auto Mode |
| 2 | Off Mode |
| 3 | See Table 5-3 |

Table 5-3 Power-up modes if Pr 01.052 = 3

| Power-down | Power-up |
|-------------------|-----------------|
| Hand | Off |
| Off | Off |
| Auto | Auto |

Auto

In Auto mode, the reference for the motor speed/frequency will be selected by the value set in Pr **00.005**.

Hand

The speed/frequency reference Pr **00.005** is automatically set to keypad reference. The motor speed is determined by the value in the keypad control mode reference Pr **01.017**, which can be adjusted by pressing the Up/Down arrows on the keypad.

When Hand is selected from Auto, Pr **01.017** will be set to the value of the *Pre-ramp reference* (Pr **01.003**) on mode transition, so the current motor speed is maintained.

If Hand mode is selected from Off mode, the motor will ramp up to the speed determined by the value in Pr **01.017**.

Off

In Off mode, the motor will be stopped. The speed/frequency reference (Pr **00.005**) is automatically set to keypad reference allowing the value in the *keypad control mode reference* (Pr **01.017**) to be modified by pressing the Up/Down arrow keys. If Hand mode is then selected, the motor will ramp up to the speed determined by the value in Pr **01.017**.

Figure 5-2 Display modes

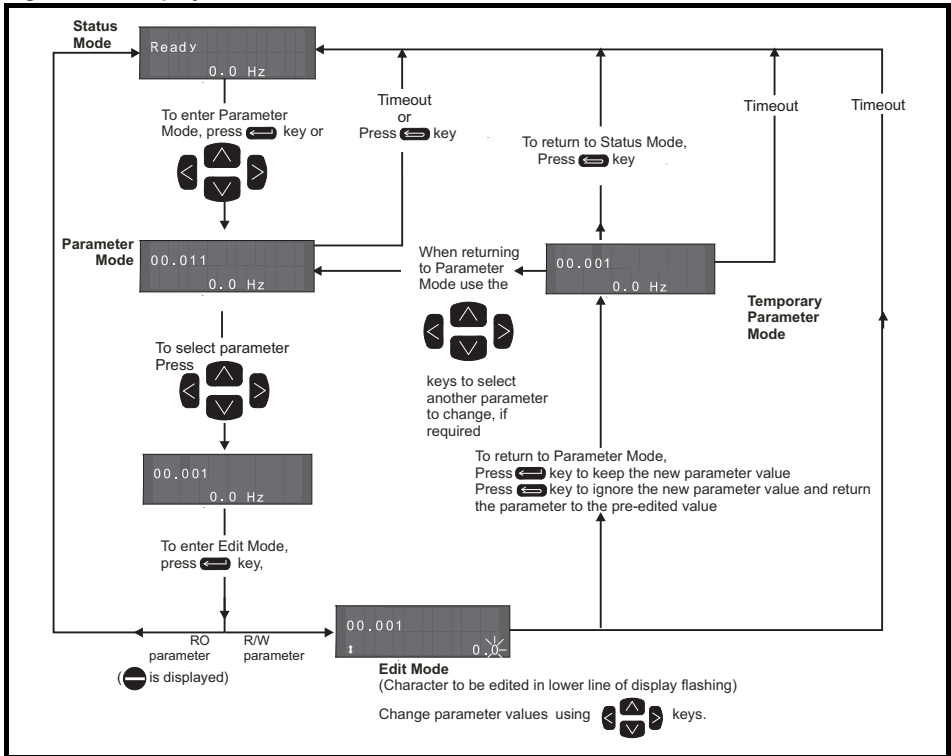

The navigation keys can only be used to move between menus if Pr 00.049 has been set to show 'All Menus'

Figure 5-3 Mode examples

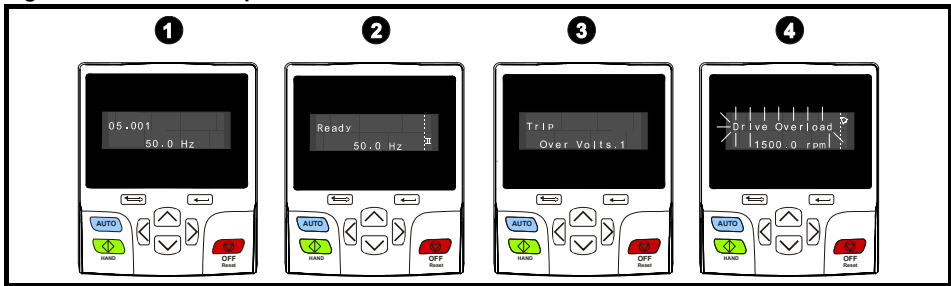

Do not change parameter values without careful consideration; incorrect values may cause damage or a safety hazard.

NOTE

When changing the values of parameters, make a note of the new values in case they need to be entered again.

NOTE

For new parameter-values to apply after the AC supply to the drive is interrupted, new values must be saved. Refer to section 5.7 *Saving parameters* on page 42.

5.3 Menu 0

Menu 0 is used to bring together various commonly used parameters for basic easy set up of the drive. Appropriate parameters are copied from the advanced menus into menu 0 and thus exist in both locations. For further information, refer to Chapter 6 *Basic parameters (Menu 0)* on page 44.

5.4 Menu structure

The drive parameter structure consists of menus and parameters. The drive initially powers up so that only Menu 0 can be viewed. The up and down arrow buttons are used to navigate between parameters and once Pr **00.049** has been set to 'All Menus' the left and right buttons are used to navigate between menus. For further information, refer to section 5.11 *Parameter access level and security* on page 43.

Figure 5-4 Menu structure

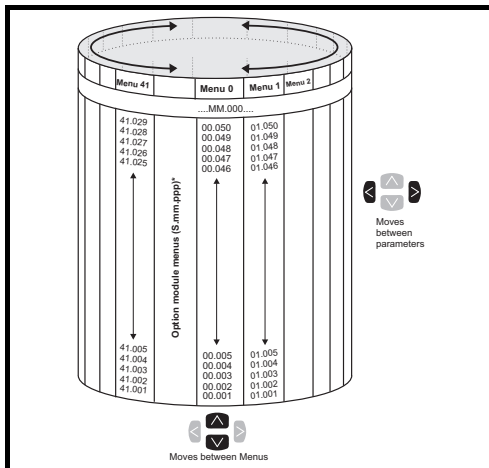

The menus and parameters roll over in both directions. i.e. if the last parameter is displayed, a further press will cause the display to rollover and show the first parameter.

When changing between menus the drive remembers which parameter was last viewed in a particular menu and thus displays that parameter.

* The option module menus (S.mm.ppp) are only displayed if option modules are installed. Where S signifies the option module slot number and the mm.ppp signifies the menu and the parameter number of the option module's internal menu and parameter.

5.5 Advanced menus

The advanced menus consist of groups or parameters appropriate to a specific function or feature of the drive. Menus 0 to 41 can be viewed on the KI-HOA-Keypad.

Table 5-4 Advanced menu descriptions

| Menu | Description |
|--------|--|
| 0 | Commonly used basic set-up parameters for quick / easy programming |
| 1 | Frequency / speed reference |
| 2 | Ramps |
| 3 | Frequency slaving, speed feedback and speed control |
| 4 | Torque and current control |
| 5 | Motor control |
| 6 | Sequencer and clock |
| 7 | Analog I/O, Temperature monitoring |
| 8 | Digital I/O |
| 9 | Programmable logic, motorized pot, binary sum, timers and scope |
| 10 | Status and trips |
| 11 | Drive set-up and identification, serial communications |
| 12 | Threshold detectors and variable selectors |
| 14 | User PID controller |
| 15 | Option module slot 1 set-up menu |
| 16 | Option module slot 2 set-up menu |
| 17 | Option module slot 3 set-up menu |
| 18 | General option module application menu 1 |
| 19 | General option module application menu 2 |
| 20 | General option module application menu 3 |
| 22 | Menu 0 set-up |
| 23 | Not allocated |
| 28 | Not allocated |
| 29 | Reserved - menu pumping functions |
| 30 | Onboard user programming application menu |
| Slot 1 | Slot 1 option menus* |
| Slot 2 | Slot 2 option menus* |
| Slot 3 | Slot 3 option menus* |

* Only displayed when the option modules are installed.

Safety Information
Product Information
Mechanical Installation
Electrical Installation
Getting started
Basic parameters (Menu 0)
Running the motor
NV / Media Card Operation
Further information
UL listing information

5.6 Changing the operating mode

Changing the operating mode returns all parameters to their default value, including the motor parameters. *User security status* (00.049) and *User security code* (00.034) are not affected by this procedure).

Procedure

Use the following procedure only if a different operating mode is required:

1. Ensure the drive is not enabled, i.e. terminal 29 is open or Pr **006.015** is OFF (0)
2. Enter either of the following values in Pr **mm.000**, as appropriate:
1253 (50 Hz AC supply frequency)
1254 (60 Hz AC supply frequency)
3. Change the setting of Pr **00.048** as follows:

| Pr 00.048 setting | | Operating mode |
|-------------------|---|---|
| | 1 | Open-loop (Induction motor) |
| | 2 | RFC-A (Induction motor without position feedback) |
| | 3 | RFC-S (Permanent magnet motor without position feedback) |

The figures in the second column apply when serial communications are used.

4. Either:

- Press the red reset button
- Toggle the reset digital input
- Carry out a drive reset through serial communications by setting Pr **10.038** to 100.

NOTE Entering 1253 or 1254 in Pr **mm.000** will only load defaults if the setting of Pr **00.048** has been changed.

5.7 Saving parameters

When changing a parameter in Menu 0, the new value is saved when pressing the Enter button to return to parameter view mode from parameter edit mode.

If parameters have been changed in the advanced menus, then the change will not be saved automatically. A save function must be carried out.

Procedure

1. Select 'Save Parameters'* in Pr **mm.000** (alternatively enter a value of 1000* in Pr **mm.000**)
2. Either:
 - Press the red reset button
 - Toggle the reset digital input, or
 - Carry out a drive reset through serial communications by setting Pr **10.038** to 100

* If the drive is in the under voltage state (i.e. when the control terminal 1 & 2 are being supplied from a low voltage DC supply) a value of 1001 must be entered into Pr **mm.000** to perform a save function.

5.8 Restoring parameter defaults

Restoring parameter defaults by this method saves the default values in the drives memory. *User security status* (00.049) and *User security code* (00.034) are not affected by this procedure.

Procedure

1. Ensure the drive is not enabled, i.e. terminal 29 is open or Pr **06.015** is OFF (0)
2. Select 'Reset 50 Hz Defs' or 'Reset 60 Hz Defs' in Pr **mm.000**. (alternatively, enter 1233 (50 Hz settings) or 1244 (60 Hz settings) in Pr **mm.000**).
3. Either:
 - Press the red  reset button
 - Toggle the reset digital input
 - Carry out a drive reset through serial communications by setting Pr **10.038** to 100

5.9 Displaying parameters with non-default values only

By selecting 'Show non-default' in Pr **mm.000** (Alternatively, enter 12000 in Pr **mm.000**), the only parameters that will be visible to the user will be those containing a non-default value. This function does not require a drive reset to become active. In order to deactivate this function, return to Pr **mm.000** and select 'No action' (alternatively enter a value of 0). Please note that this function can be affected by the access level enabled, refer to section 5.11 *Parameter access level and security* on page 43 for further information regarding access level.

5.10 Displaying destination parameters only

By selecting 'Destinations' in Pr **mm.000** (Alternatively enter 12001 in Pr **mm.000**), the only parameters that will be visible to the user will be destination parameters. This function does not require a drive reset to become active. In order to deactivate this function, return to Pr **mm.000** and select 'No action' (alternatively enter a value of 0).

Please note that this function can be affected by the access level enabled, refer to section 5.11 *Parameter access level and security* for further information regarding access level.

5.11 Parameter access level and security

The parameter access level determines whether the user has access to Menu 0 only or to all the advanced menus (Menus 1 to 41) in addition to Menu 0. The User Security determines whether the access to the user is read only or read write. Both the User Security and Parameter Access Level can operate independently of each other as shown in Table 5-5.

Table 5-5 Parameter access level and security

| User security status (11.044) | Access level | User security | Menu 0 status | Advanced menu status |
|-------------------------------|------------------|---------------|---------------|----------------------|
| 0 | Menu 0 | Open | RW | Not visible |
| | | Closed | RO | Not visible |
| 1 | All Menus | Open | RW | RW |
| | | Closed | RO | RO |
| 2 | Read-only Menu 0 | Open | RO | Not visible |
| | | Closed | RO | Not visible |
| 3 | Read-only | Open | RO | RO |
| | | Closed | RO | RO |
| 4 | Status only | Open | Not visible | Not visible |
| | | Closed | Not visible | Not visible |
| 5 | No access | Open | Not visible | Not visible |
| | | Closed | Not visible | Not visible |

The default settings of the drive are Parameter Access Level Menu 0 and User Security Open i.e. read / write access to Menu 0 with the advanced menus not visible.

6 Basic parameters (Menu 0)

| Parameter | | Range | | | Default | | | Type | | | | | | | |
|-----------|--|----------|--|-------------------------------|--------------|----------------------------------|--|------|-----|-----|-----|----|----|--|----|
| | | OL | RFC-A | RFC-S | OL | RFC-A | RFC-S | | | | | | | | |
| 00.001 | Minimum Reference Clamp | {01.007} | ±VM_NEGATIVE_REF_CLAMP1 Hz / rpm | | | 0 Hz / rpm | | | RW | Num | | | | | US |
| 00.002 | Maximum Reference Clamp1 | {01.006} | ±VM_POSITIVE_REF_CLAMP1 Hz / rpm | | | 50 Hz: 50.0 Hz 60 Hz: 60.0 Hz | 50 Hz: 1500.0 rpm 60 Hz: 1800.0 rpm | RW | Num | | | | | | US |
| 00.003 | Acceleration Rate 1 | {02.011} | ±VM_ACCEL_RATE s to Pr 01.006 | ±VM_ACCEL_RATE s to Pr 01.006 | | 20.0 s to Pr 01.006 | 20,000 s to Pr 01.006 | RW | Num | | | | | | US |
| 00.004 | Deceleration Rate 1 | {02.021} | ±VM_ACCEL_RATE s to Pr 01.006 | ±VM_ACCEL_RATE s to Pr 01.006 | | 20.0 s to Pr 01.006 | 20,000 s to Pr 01.006 | RW | Num | | | | | | US |
| 00.005 | Reference Selector | {01.014} | A1 A2 (0), A1 Preset (1), A2 Preset (2), Preset (3), Keypad (4), Precision (5), Keypad Ref (6) | | | A1 A2 (0) | | | RW | Txt | | | | | US |
| 00.006 | Symmetrical Current Limit | {04.007} | ±VM_MOTOR1_CURRENT_LIMIT % | | | 110.0 % | 110.0 % | RW | Num | | RA | | | | US |
| 00.007 | Open-loop Control Mode / Action On Enable | {05.014} | Ur S (0), Ur l (1), Fixed (2), Ur Auto (3), Ur l (4), Square (5), Current 1P (6) | | | Ur l (4) | | | RW | Txt | | | | | US |
| | Speed Controller Proportional Gain Kp1 | {03.010} | 0.0000 to 200.000 s/rad | | | 0.0300 s/rad | | | RW | Num | | | | | US |
| 00.008 | Low Frequency Voltage Boost | {05.015} | 0.0 to 25.0 % | | | 3.0 % | | | RW | Num | | | | | US |
| | Speed Controller Integral Gain Ki1 | {03.011} | 0.00 to 655.35 s ² /rad | | | 0.10 s ² /rad | | | RW | Num | | | | | US |
| 00.009 | Dynamic V to F Select | {05.013} | Off (0) or On (1) | | | Off (0) | | | RW | Bit | | | | | US |
| | Speed Controller Differential Feedback Gain Kd 1 | {03.012} | 0.00000 to 0.65535 1/rad | | | 0.00000 1/rad | | | RW | Num | | | | | US |
| 00.010 | Motor Rpm | {05.004} | ±180000 rpm | | | | | | RO | Num | ND | NC | PT | | FI |
| | Speed Feedback | {03.002} | ±VM_SPEED rpm | | | | | | RO | Num | ND | NC | PT | | FI |
| 00.011 | Output Frequency | {05.001} | ±VM_SPEED_FREQ_REF Hz | | | | | | RO | Num | ND | NC | PT | | FI |
| 00.012 | Current Magnitude | {04.001} | ±VM_DRIVE_CURRENT_UNIPOLAR A | | | | | | RO | Bit | ND | NC | PT | | FI |
| 00.013 | Torque Producing Current | {04.002} | ±VM_DRIVE_CURRENT A | | | | | | RO | Bit | ND | NC | PT | | FI |
| 00.015 | Ramp Mode Select | {02.004} | Standard (1), Std boost (2) | | Standard (1) | | Standard (1) | | | RW | Txt | | | | US |
| 00.017 | Digital Input 6 Destination | {08.026} | 0.000 to 59.999 | | | 0.000 | | | RW | Num | DE | | PT | | US |
| | Current Reference Filter 1 Time Constant | {04.012} | 0.0 to 25.0 ms | | | 1.0 ms | | | RW | Num | | | | | US |
| 00.019 | Analog Input 1 Mode | {07.007} | 4-20mA Low (-4), 20-4mA Low (-3), 4-20mA Hold (-2), 20-4mA Hold (-1), 0-20mA (0), 20-0mA (1), 4-20mA Trip (2), 20-4mA Trip (3), 4-20mA (4), 20-4mA (5), Volt (6), Therm Short Cct (7), Thermistor (8), Therm No Trip (9) | | | 4-20mA (4) | | | RW | Txt | | | | | US |
| 00.020 | Analog Input 1 Destination | {07.010} | 00.000 to 59.999 | | | 01.036 | | | RW | Num | DE | | PT | | US |
| 00.021 | Analog Input 2 Mode | {07.011} | 4-20mA Low (-4), 20-4mA Low (-3), 4-20mA Hold (-2), 20-4mA Hold (-1), 0-20mA (0), 20-0mA (1), 4-20mA Trip (2), 20-4mA Trip (3), 4-20mA (4), 20-4mA (5), Volt (6), Therm Short Cct (7), Thermistor (8), Therm No Trip (9) | | | Volt (6) | | | RW | Txt | | | | | US |

| Parameter | | | Range | | | Default | | | Type | | | | | |
|-----------|--------------------------------------|----------|--|----------------------|-------------------------|--|--|-----------------|------|-----|-----|----|----|----|
| | | | OL | RFC-A | RFC-S | OL | RFC-A | RFC-S | | | | | | |
| 00.022 | Bipolar Reference Enable | {01.010} | Off (0) or On (1) | | | Off (0) | | | RW | Bit | | | | US |
| 00.024 | Preset Reference 1 | {01.021} | ±VM_SPEED_FREQ_REF Hz / rpm | | | 0.0 Hz / rpm | | | RW | Num | | | | US |
| 00.025 | Preset Reference 2 | {01.022} | ±VM_SPEED_FREQ_REF Hz / rpm | | | 0.0 Hz / rpm | | | RW | Num | | | | US |
| 00.026 | Preset Reference 3 | {01.023} | ±VM_SPEED_FREQ_REF Hz | | | 0.0 Hz | | | RW | Num | | | | US |
| | Overspeed Threshold | {03.008} | 0 to 40000 rpm | | | | 0 rpm | | | RW | Num | | | US |
| 00.027 | Preset Reference 4 | {01.024} | ±VM_SPEED_FREQ_REF Hz | | | 0.0 Hz | | | RW | Num | | | | US |
| 00.029 | NV Media Card Data Previously Loaded | {11.036} | 0 to 999 | | | 0 | | | RO | Num | | NC | PT | |
| 00.030 | Parameter Cloning | {11.042} | None (0), Read (1), Program (2), Auto (3), Boot (4) | | | None (0) | | | RW | Txt | | NC | | US |
| 00.031 | Rated Voltage | {11.033} | 200 V (0), 400 V (1), 575 V (2), 690 V (3) | | | | | | RO | Txt | ND | NC | PT | |
| 00.033 | Catch A Spinning Motor | {06.009} | Disable (0), Enable (1), Fwd Only (2), Rev Only (3) | | | Disable (0) | | | RW | Txt | | | | US |
| | Motor Parameter Adaptive Control | {05.016} | 0 to 2 | | | | 0 | | | RW | Num | | | US |
| 00.034 | User Security Code | {11.030} | 0 to 2147483647 | | | 0 | | | RW | Num | ND | NC | PT | US |
| 00.035 | Serial Mode | {11.024} | 8 2 NP (0), 8 1 NP (1), 8 1 EP (2), 8 1 OP (3), 8 2 NP M (4), 8 1 NP M (5), 8 1 EP M (6), 8 1 OP M (7), 7 2 NP (8), 7 1 NP (9), 7 1 EP (10), 7 1 OP (11), 7 2 NP M (12), 7 1 NP M (13), 7 1 EP M (14), 7 1 OP M (15) | | | 8 2 NP (0) | | | RW | Txt | | | | US |
| 00.036 | Serial Baud Rate | {11.025} | 300 (0), 600 (1), 1200 (2), 2400 (3), 4800 (4), 9600 (5), 19200 (6), 38400 (7), 57600 (8), 76800 (9), 15200 (10) | | | 19200 (6) | | | RW | Txt | | | | US |
| 00.037 | Serial Address | {11.023} | 1 to 247 | | | 1 | | | RW | Num | | | | US |
| 00.038 | Current Controller Kp Gain | {04.013} | 0 to 30000 | | | 20 | 150 | | RW | Num | | | | US |
| 00.039 | Current Controller Ki Gain | {04.014} | 0 to 30000 | | | 40 | 2000 | | RW | Num | | | | US |
| 00.040 | Auto-tune | {05.012} | 0 to 2 | 0 to 5 | 0 to 6 | 0 | | | RW | Num | | NC | | |
| 00.041 | Maximum Switching Frequency | {05.018} | 2 kHz (0), 3 kHz (1), 4 kHz (2), 6 kHz (3), 8 kHz (4), 12 kHz (5), 16 kHz (6) | | | 3 kHz (1) | | | RW | Txt | | RA | | US |
| 00.042 | Number Of Motor Poles | {05.011} | Automatic (0) to 480 Poles (240) | | | Automatic (0) | 6 Poles (3) | | RW | Num | | | | US |
| 00.043 | Rated Power Factor | {05.010} | 0.000 to 1.000 | | | | 0.850 | | | RW | Num | | RA | US |
| 00.044 | Rated Voltage | {05.009} | ±VM_AC_VOLTAGE_SET V | | | 200V drive: 230V 50Hz default 400V drive: 400V 60Hz default 400V drive: 460V 575V drive: 575V 690V drive: 690V | | | RW | Num | | RA | | US |
| 00.045 | Rated Speed | {05.008} | 0 to 33000 rpm | 0.00 to 33000.00 rpm | | Eur - 1500 rpm USA - 1800 rpm | Eur - 1450.0 0 rpm USA - 1750.0 0 rpm | 3000.0 0 rpm | RW | Num | | | | US |
| 00.046 | Rated Current | {05.007} | ±VM_RATED_CURRENT A | | | Maximum Rated Current (11.060) A | | | RW | Num | | RA | | US |
| 00.047 | Rated Frequency | {05.006} | 0.0 to 550.0 Hz | | | | 50Hz: 50.0 60Hz: 60.0 | | | RW | Num | | | US |
| | Volts per 1000 rpm | {05.033} | | | 0 to 10000 V / 1000 rpm | | | 98 V / 1000 rpm | RW | Num | | | | US |
| 00.048 | User Drive Mode | {11.031} | Open-loop (1), RFC-A (2), RFC-S (3) | | | Open-loop (1) | RFC-A (2) | RFC-S (3) | RW | Txt | ND | NC | PT | |

| |
|---------------------------|
| Safety Information |
| Product Information |
| Mechanical Installation |
| Electrical Installation |
| Getting started |
| Basic parameters (Menu 0) |
| Running the motor |
| NV Media Card Operation |
| Further Information |
| UL listing Information |

| Parameter | | | Range | | | Default | | | Type | | | | | |
|-----------|--|----------|---|-------|--------------------------------|------------|-------|-----------------|------|-----|----|----|----|----|
| | | | OL | RFC-A | RFC-S | OL | RFC-A | RFC-S | | | | | | |
| 00.049 | User Security Status | {11.044} | Menu 0 (0), All Menus (1), Read-only Menu 0 (2), Read-only (3), Status Only (4), No Access (5) | | | Menu 0 (0) | | | RW | Txt | ND | | PT | |
| 00.050 | Software Version | {11.029} | 0 to 99999999 | | | | | | RO | Num | ND | NC | PT | |
| 00.051 | Action On Trip Detection | {10.037} | 00000 to 11111 | | | 00000 | | | RW | Bin | | | | US |
| 00.052 | Reset Serial Communications | {11.020} | Off (0) or On (1) | | | Off (0) | | | RW | Bit | ND | NC | | |
| 00.053 | Motor Thermal Time Constant 1 | {04.015} | 1.0 to 3000.0 s | | | 89.0 s | | | RW | Num | | | | US |
| 00.054 | RFC Low Speed Mode | {05.064} | | | Injection (0), Non-salient (1) | | | Non-salient (1) | RW | Txt | | | | US |
| 00.055 | Low Speed Sensorless Mode Current | {05.071} | | | 0.0 to 1000.0 % | | | 20.0 % | RW | Num | | RA | | US |
| 00.056 | No-load Lq | {05.072} | | | 0.000 to 500.000 mH | | | 0.000 mH | RW | Num | | RA | | US |
| 00.057 | Iq Test Current or Inductance Measurement | {05.075} | | | 0 to 200 % | | | 100 % | RW | Num | | | | US |
| 00.058 | Phase Offset At Iq Test Current | {05.077} | | | ±90.0 ° | | | 0.0 ° | RW | Num | | RA | | US |
| 00.059 | Lq At The Defined Iq Test Current | {05.078} | | | 0.000 to 500.000 mH | | | 0.000 mH | RW | Num | | RA | | US |
| 00.060 | Id Test Current for Inductance Measurement | {05.082} | | | -100 to 0 % | | | -50 % | RW | Num | | | | US |
| 00.061 | Lq At The Defined Id Test Current | {05.084} | | | 0.000 to 500.000 mH | | | 0.000 mH | RW | Num | | RA | | US |

| RW | Read / Write | RO | Read only | Num | Number parameter | Bit | Bit parameter | Txt | Text string | Bin | Binary parameter | FI | Filtered |
|----|------------------|----|------------|-----|---------------------|-----|------------------|-----|-------------|-----|------------------|----|-------------|
| ND | No default value | NC | Not copied | PT | Protected parameter | RA | Rating dependent | US | User save | PS | Power-down save | DE | Destination |

6.1 Parameter descriptions

6.1.1 Pr mm.000

Pr **mm.000** is available in all menus, commonly used functions are provided as text strings in Pr **mm.000** shown in Table 6-1. The functions in Table 6-1 can also be selected by entering the appropriate numeric values (as shown in Table 6-2) in Pr **mm.000**. For example, enter 7001 in Pr **mm.000** to erase the file in NV media card location 001.

Table 6-1 Commonly used functions in Pr mm.000

| String | Action |
|-------------------------|--|
| Save parameters | Save parameters when under voltage is not active and low voltage threshold is not active |
| Load file 1 | Load the drive parameters or user program file from NV media card file 001 |
| Save to file 1 | Transfer the drive parameters to parameter file 001 |
| Load file 2 | Load the drive parameters or user program file from NV media card file 002 |
| Save to file 2 | Transfer the drive parameters to parameter file 002 |
| Load file 3 | Load the drive parameters or user program file from NV media card file 003 |
| Save to file 3 | Transfer the drive parameters to parameter file 003 |
| Show non-default | Displays parameters that are different from defaults |
| Destinations | Displays parameters that are set |
| Reset 50Hz Defs | Load parameters with standard (50 Hz) defaults |
| Reset 60Hz Defs | Load parameters with US (60 Hz) defaults |
| Reset modules | Reset all option modules |
| Read Enc.NP P1 | No function on F300 |
| Read Enc.NP P2 | No function on F300 |

Safety Information

Product Information

Mechanical Installation

Electrical Installation

Getting started

Basic parameters (Menu 0)

Running the motor

NV Media Card Operation

Further information

UL listing information

Table 6-2 Functions in Pr mm.000

| Value | Action |
|--------------|---|
| 1000 | Save parameters when <i>Under Voltage Active</i> (Pr 10.016) is not active and <i>Low Under Voltage Threshold Select</i> mode (Pr 06.067 = Off) is not active. |
| 1001 | Save parameter under all conditions |
| 1070 | Reset all option modules |
| 1233 | Load standard (50 Hz) defaults |
| 1234 | Load standard (50 Hz) defaults to all menus except option module menus (i.e 15 to 20 and 24 to 28) |
| 1244 | Load US (60 Hz) defaults |
| 1245 | Load US (60 Hz) defaults to all menus except option module menus (i.e 15 to 20 and 24 to 28) |
| 1253 | Change drive mode and load standard (50 Hz) defaults |
| 1254 | Change drive mode and load US (60 Hz) defaults |
| 1255 | Change drive mode and load standard (50 Hz) defaults except for menus 15 to 20 and 24 to 28 |
| 1256 | Change drive mode and load US (60 Hz) defaults except for menus 15 to 20 and 24 to 28 |
| 1299 | Reset {Stored HF} trip. |
| 2001* | Create a boot file on a non-volatile media card based on the present drive parameters including all Menu 20 parameters |
| 4yyy* | NV media card: Transfer the drive parameters to parameter file xxx |
| 5yyy* | NV media card: Transfer the onboard user program to onboard user program file xxx |
| 6yyy* | NV media card: Load the drive parameters from parameter file xxx or the onboard user program from onboard user program file xxx |
| 7yyy* | NV media card: Erase file xxx |
| 8yyy* | NV Media card: Compare the data in the drive with file xxx |
| 9555* | NV media card: Clear the warning suppression flag |
| 9666* | NV media card: Set the warning suppression flag |
| 9777* | NV media card: Clear the read-only flag |
| 9888* | NV media card: Set the read-only flag |
| 9999* | NV media card: Erase and format the NV media card |
| 12000** | Only display parameters that are different from their default value. This action does not require a drive reset. |
| 12001** | Only display parameters that are used to set-up destinations (i.e. DE format bit is 1). This action does not require a drive reset. |

* See section 8 *NV Media Card Operation* on page 67 for more information on these functions.

** These functions do not require a drive reset to become active. All other functions require a drive reset to initiate the function.

| | | | | | | | | | |
|--------------------|---------------------|-------------------------|-------------------------|-----------------|----------------------------------|-------------------|-------------------------|---------------------|------------------------|
| Safety information | Product information | Mechanical installation | Electrical installation | Getting started | Basic parameters (Menu 0) | Running the motor | NV Media Card Operation | Further information | UL listing information |
|--------------------|---------------------|-------------------------|-------------------------|-----------------|----------------------------------|-------------------|-------------------------|---------------------|------------------------|

Figure 6-1 Menu 0 logic diagram

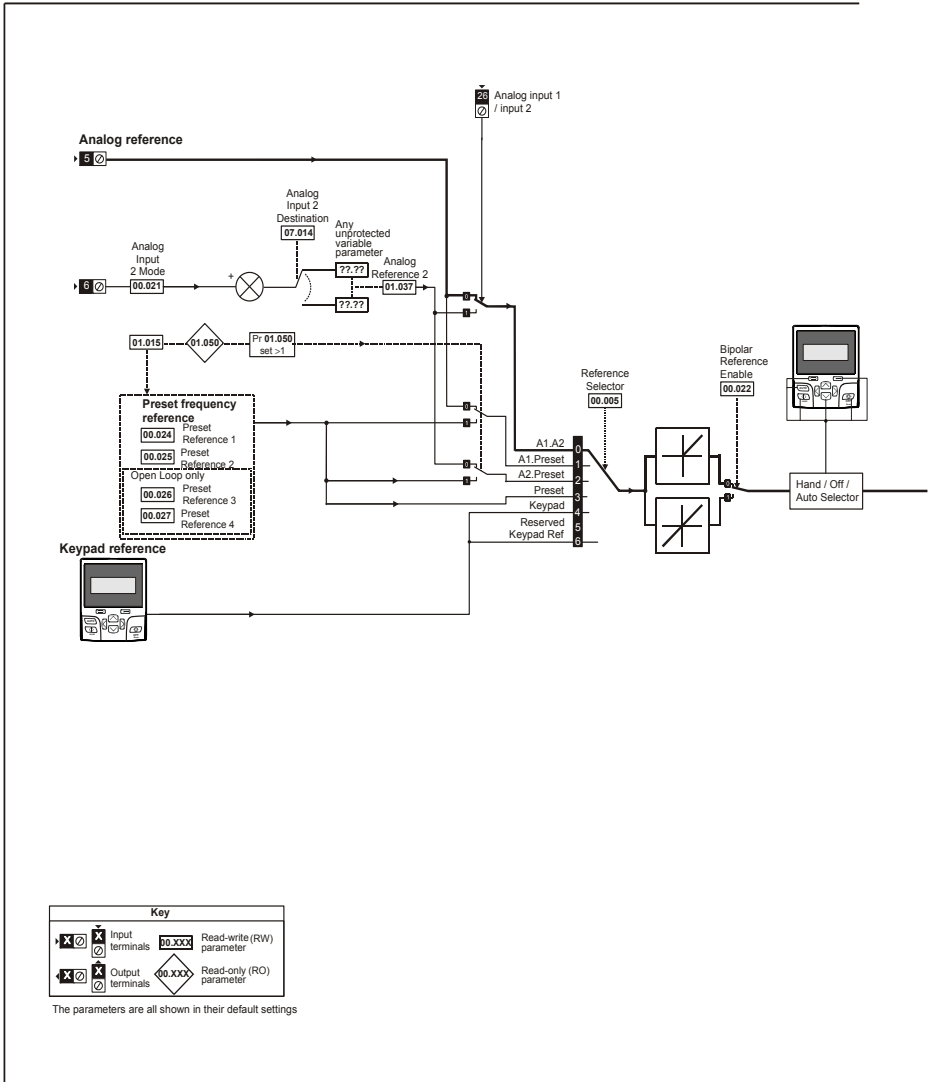

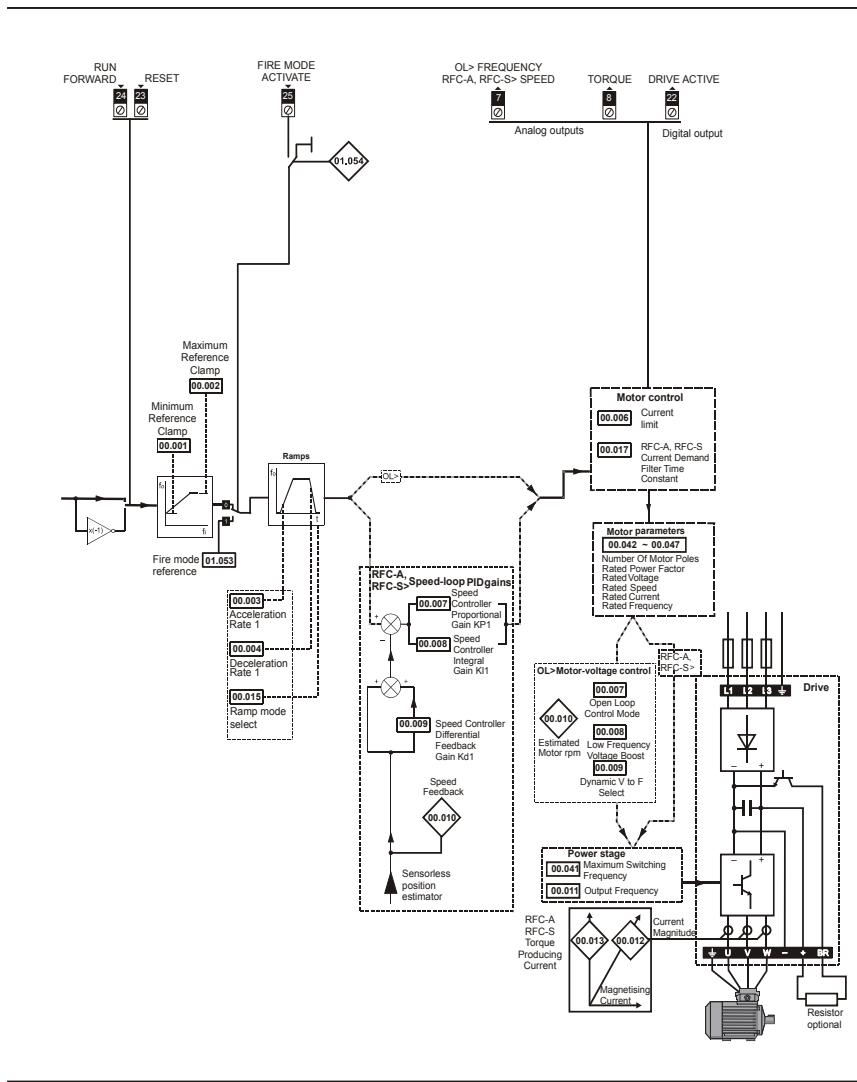

7 Running the motor

This chapter takes the new user through all the essential steps to running a motor for the first time, in each of the possible operating modes.



Ensure that no damage or safety hazard could arise from the motor starting unexpectedly.



The values of the motor parameters affect the protection of the motor.

The default values in the drive should not be relied upon.

It is essential that the correct value is entered in Pr **00.046 Rated Current**. This affects the thermal protection of the motor.



If the drive is started using the keypad it will run to the speed defined by the keypad

reference (Pr **02.017**). This may not be acceptable depending on the application. The user must check in Pr **01.017** and ensure that the keypad reference has been set to 0.



If the intended maximum speed affects the safety of the machinery, additional independent over-speed protection must be used.

7.1 Quick start connections

7.1.1 Basic requirements

This section shows the basic connections which must be made for the drive to run in the required mode. For minimal parameter settings to run in each mode please see the relevant part of section 7.2 *Quick Start / start-up* on page 57.

Table 7-1 Minimum control connection requirements for each control mode

| Drive control method | Requirements |
|----------------------|---|
| Terminal mode | Drive enable Speed / Torque reference Run forward / Run reverse |
| Keypad mode | Drive enable |
| Communications | Drive enable Communications link |

Table 7-2 Minimum control connection requirements for each mode of operation

| Operating mode | Requirements |
|--|---|
| Open loop mode | Induction motor |
| RFC - A sensorless (without feedback position) | Induction motor with speed feedback |
| RFC - S sensorless (without position feedback) | Permanent magnet motor with speed and position feedback |

Figure 7-1 Minimum connections to get the motor running in any operating mode (size 3 and 4)

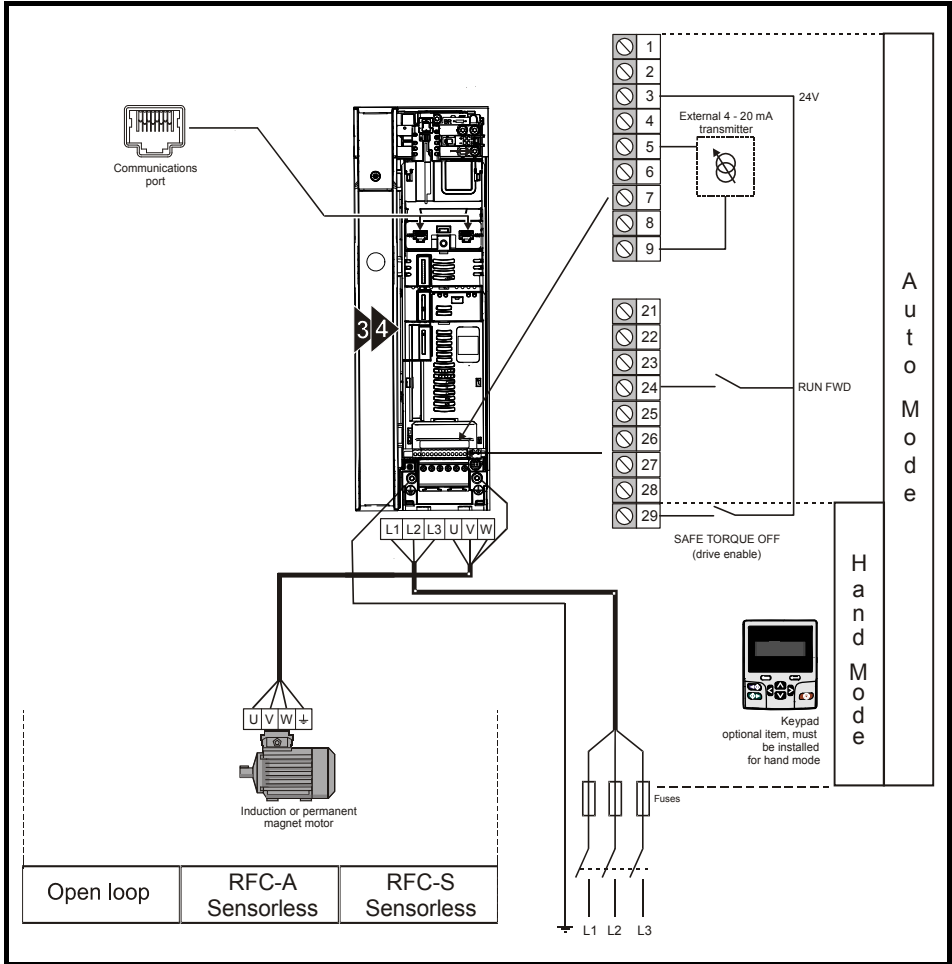

| |
|---------------------------|
| Safety information |
| Product information |
| Mechanical installation |
| Electrical installation |
| Getting started |
| Basic parameters (Menu 0) |
| Running the motor |
| NV Media Card Operation |
| Further information |
| UL listing information |

Figure 7-2 Minimum connections to get the motor running in any operating mode (size 5)

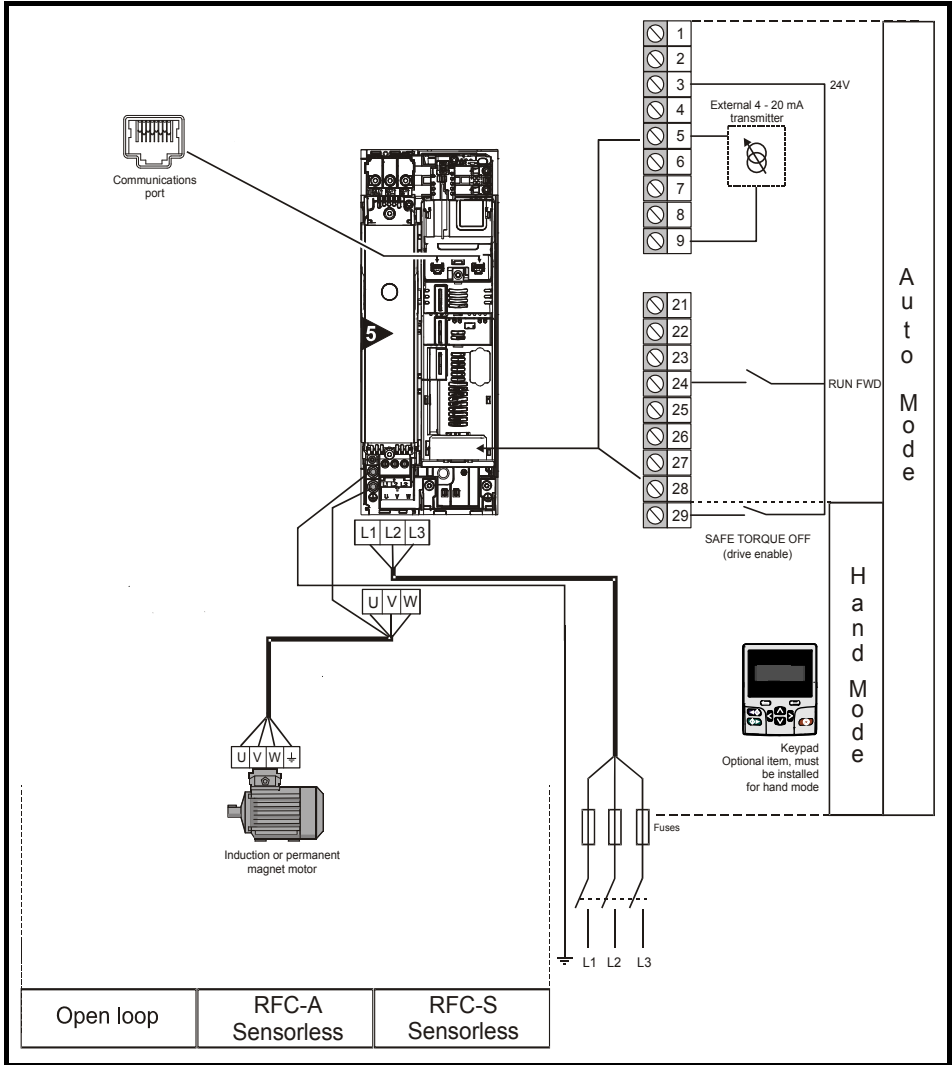
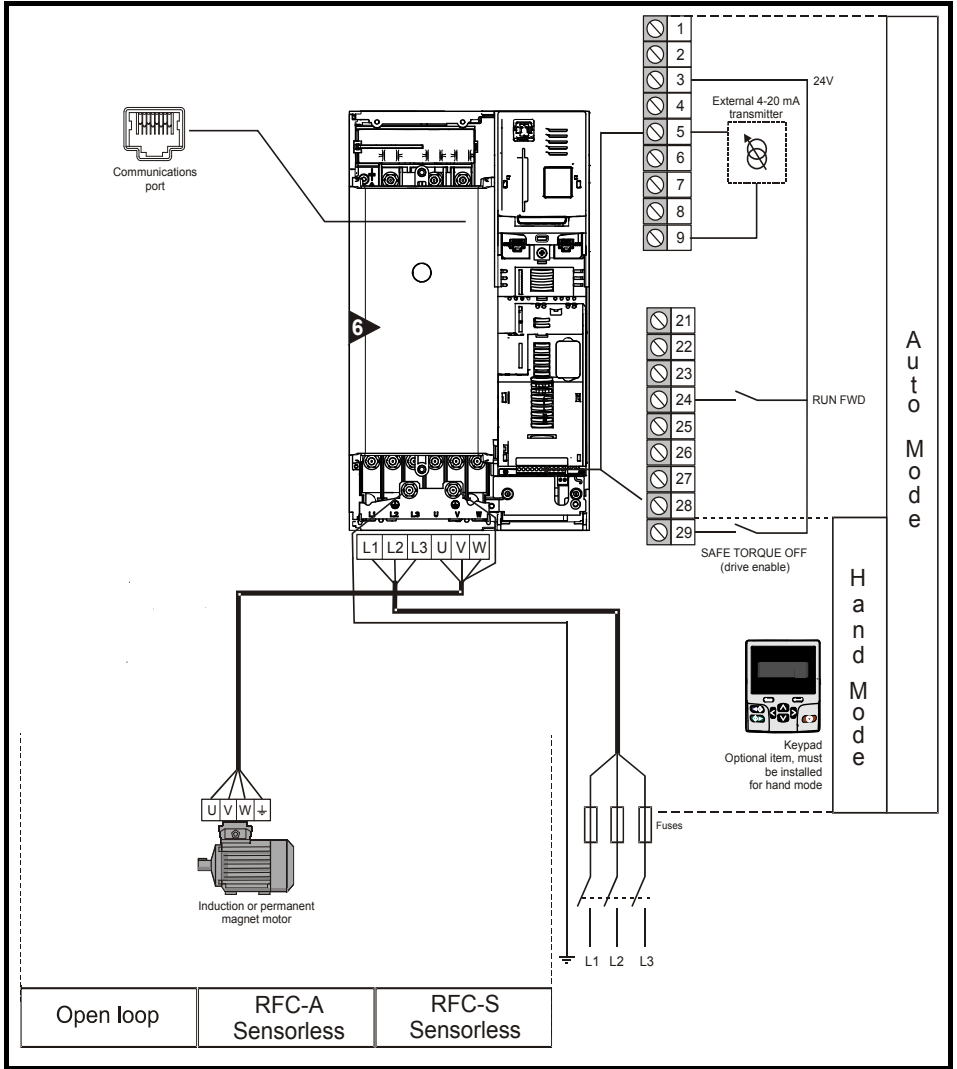
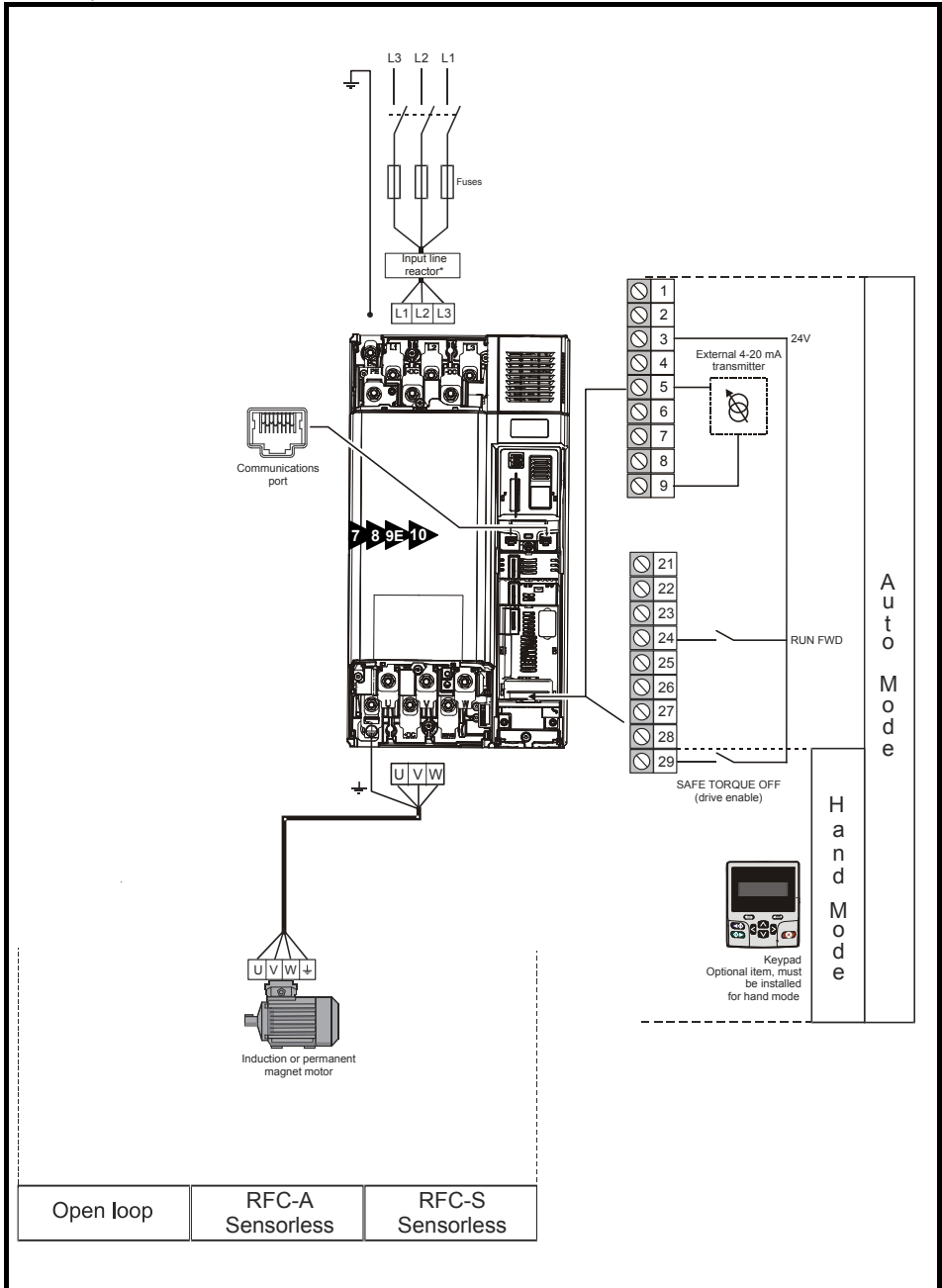

Figure 7-3 Minimum connections to get the motor running in any operating mode (size 6)



| |
|---------------------------|
| Safety information |
| Product information |
| Mechanical installation |
| Electrical installation |
| Getting started |
| Basic parameters (Menu 0) |
| Running the motor |
| NV Media Card Operation |
| Further information |
| UL listing information |

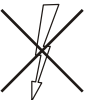

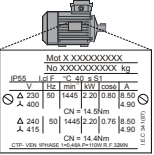
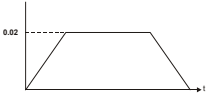
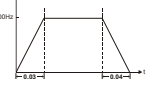

Figure 7-4 Minimum connections to get the motor running in any operating mode (size 7 onwards)



*Required for size 9E and 10.

7.2 Quick Start / start-up

7.2.1 Open loop

| Action | Detail | |
|---------------------------------------|---|--|
| Before power-up | Ensure: <ul style="list-style-type: none"> The drive enable signal is not given (terminal 29) Run signal is not given Motor is connected |  |
| Power-up the drive | Verify that Open Loop mode is displayed as the drive powers up. If the mode is incorrect see section 5.6 <i>Changing the operating mode</i> on page 42 . Ensure that the drive displays 'Inhibit' |  |
| Enter motor nameplate details | Enter: <ul style="list-style-type: none"> Motor rated frequency in Pr 00.047 (Hz) Motor rated current in Pr 00.046 (A) Motor rated speed in Pr 00.045 (rpm) Motor rated voltage in Pr 00.044 (V) - check if Δ or Y connection |  |
| Set maximum frequency | Enter: <ul style="list-style-type: none"> Maximum frequency in Pr 00.002 (Hz) |  |
| Set acceleration / deceleration rates | Enter: <ul style="list-style-type: none"> Acceleration rate in Pr 00.003 (s to Pr 1.006) Deceleration rate in Pr 00.004 (s to Pr 1.006) |  |
| Motor thermistor set-up | The motor thermistor can be selected in Pr 07.011 . Refer to Pr 07.011 for further information. |  |

Safety information

Product information

Mechanical installation

Electrical installation

Getting started



Basic parameters (Menu 0)

Running the motor

NV Media Card Operation



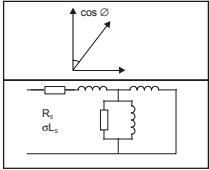

Further information

UL listing information

| Action | Detail | |
|-----------------|---|--|
| Autotune | <p>The drive is able to perform either a stationary or a rotating autotune. The motor must be at a standstill before an autotune is enabled. A rotating autotune should be used whenever possible so the measured value of power factor of the motor is used by the drive.</p> <div data-bbox="219 252 770 448" style="border: 1px solid black; padding: 5px;">  <p>WARNING</p> <p>A rotating autotune will cause the motor to accelerate up to $\frac{2}{3}$ base speed in the direction selected regardless of the reference provided. Once complete the motor will coast to a stop. The enable signal must be removed before the drive can be made to run at the required reference. The drive can be stopped at any time by removing the run signal or removing the drive enable.</p> </div> <ul style="list-style-type: none"> A stationary autotune can be used when the motor is loaded and it is not possible to uncouple the load from the motor shaft. A stationary autotune measures stator resistance and transient inductance of the motor and values relating to deadtime compensation from the drive. These are required for good performance in vector control modes. A stationary autotune does not measure the power factor of the motor so the value on the motor nameplate must be entered into Pr 00.043. A rotating autotune should only be used if the motor is uncoupled. A rotating autotune first performs a stationary autotune before rotating the motor at $\frac{2}{3}$ base speed in the direction selected. The rotating autotune measures the power factor of the motor. <p>To perform an autotune:</p> <ul style="list-style-type: none"> Set Pr 00.040 = 1 for a stationary autotune or set Pr 00.040 = 2 for a rotating autotune Close the Drive Enable signal (terminal 31). The drive will display 'Ready'. Press the green <i>hand</i> button. The upper row of the display will flash 'Auto Tune' while the drive is performing the autotune. Wait for the drive to display 'Ready' or 'Inhibit' and for the motor to come to a standstill. Remove the drive enable from the drive. |  |
| Save parameters | <p>Select 'Save Parameters' in Pr mm.000 (alternatively enter a value of 1000 in Pr mm.000) and press the red  reset button or toggle the reset digital input.</p> | |
| Run | <p>Drive is now ready to run</p>  | |

7.2.2 RFC-A mode (Sensorless)

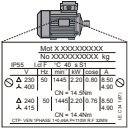
Induction motor with sensorless control

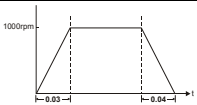
| Action | Detail | |
|---------------------------------------|---|--|
| Before power-up | Ensure: <ul style="list-style-type: none"> The drive enable signal is not given (terminal 29) Run signal is not given Motor is connected |  |
| Power-up the drive | Verify that RFC-A mode is displayed as the drive powers up. If the mode is incorrect see section 5.6 <i>Changing the operating mode</i> on page 42, otherwise restore parameter defaults (see section 5.8 <i>Restoring parameter defaults</i> on page 43). Ensure that the drive displays 'Inhibit' |  |
| Enter motor nameplate details | Enter: <ul style="list-style-type: none"> Motor rated frequency in Pr 00.047 (Hz) Motor rated current in Pr 00.046 (A) Motor rated speed in Pr 00.045 (rpm) Motor rated voltage in Pr 00.044 (V) - check if Δ or Δ connection |  |
| Set maximum speed | Enter: <ul style="list-style-type: none"> Maximum speed in Pr 00.002 (rpm) |  |
| Set acceleration / deceleration rates | Enter: <ul style="list-style-type: none"> Acceleration rate in Pr 00.003 (s to Pr 01.006) Deceleration rate in Pr 00.004 (s to Pr 01.006) |  |

Safety information

Product information

Mechanical installation

Electrical installation

Getting started



Basic parameters (Menu 0)

Running the motor

NV / Media Card Operation

Further information

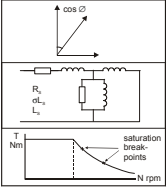
UL listing information

| Action | Detail | |
|-----------------|---|---|
| Autotune | <p>The drive is able to perform either a stationary or a rotating autotune. The motor must be at a standstill before an autotune is enabled. A stationary autotune will give moderate performance whereas a rotating autotune will give improved performance as it measures the actual values of the motor parameters required by the drive.</p> <p>NOTE It is highly recommended that a rotating autotune is performed (Pr 00.040 set to 2).</p> <div data-bbox="255 331 775 531" style="border: 1px solid black; padding: 5px;">  <p>A rotating autotune will cause the motor to accelerate up to $\frac{2}{3}$ base speed in the direction selected regardless of the reference provided. Once complete the motor will coast to a stop. The enable signal must be removed before the drive can be made to run at the required reference. The drive can be stopped at any time by removing the run signal or removing the drive enable.</p> </div> <ul style="list-style-type: none"> A stationary autotune can be used when the motor is loaded and it is not possible to uncouple the load from the motor shaft. The stationary autotune measures the stator resistance and transient inductance of the motor and values relating to deadtime compensation from the drive. Measured values are used to calculate the current loop gains, and at the end of the test the values in Pr 00.038 and Pr 00.039 are updated. A stationary autotune does not measure the power factor of the motor so the value on the motor nameplate must be entered into Pr 00.043. A rotating autotune should only be used if the motor is uncoupled. A rotating autotune first performs a stationary autotune before rotating the motor at $\frac{2}{3}$ base speed in the direction selected. The rotating autotune measures the stator inductance of the motor and calculates the power factor. <p>To perform an autotune:</p> <ul style="list-style-type: none"> Set Pr 00.040 = 1 for a stationary autotune or set Pr 00.040 = 2 for a rotating autotune Close the drive enable signal (terminal 29). The drive will display 'Ready' or 'Inhibit'. Press the green <i>hand</i> button. The lower display will flash 'Autotune' while the drive is performing the autotune. Wait for the drive to display 'Ready' or 'Inhibit' and for the motor to come to a standstill. Remove the drive enable from the drive. |  |
| Save parameters | <p>Select 'Save Parameters' in Pr mm.000 (alternatively enter a value of 1000 in Pr mm.000) and press red  reset button or toggle the reset digital input.</p> | |
| Run | <p>Drive is now ready to run</p> |  |

7.2.3 RFC-S mode (Sensorless) Permanent magnet motor without position feedback

| Action | Detail | |
|---------------------------------------|--|--|
| Before power-up | Ensure: <ul style="list-style-type: none"> The drive enable signal is not given (terminal 29). Run signal is not given Motor is connected | |
| Power-up the drive | Verify that RFC-S mode is displayed as the drive powers up. If the mode is incorrect see section 5.6 <i>Changing the operating mode</i> on page 42, otherwise restore parameter defaults (see section 5.8 <i>Restoring parameter defaults</i> on page 43). Ensure that the drive displays 'inhibit' | |
| Enter motor nameplate details | Enter: <ul style="list-style-type: none"> Motor rated current in Pr 00.046 (A) Number of poles in Pr 00.042 Motor rated voltage in Pr 00.044 (V) | |
| Set maximum speed | Enter: <ul style="list-style-type: none"> Maximum speed in Pr 00.002 (rpm) | |
| Set acceleration / deceleration rates | Enter: <ul style="list-style-type: none"> Acceleration rate in Pr 00.003 (s to Pr 01.006) Deceleration rate in Pr 00.004 (s to Pr 01.006) | |
| Autotune | <p>The drive is able to perform a stationary autotune. The motor must be at a standstill before an autotune is enabled. A stationary autotune will give moderate performance.</p> <ul style="list-style-type: none"> A stationary autotune is performed to locate the flux axis of the motor. The stationary autotune measures the stator resistance, inductance in flux axis, inductance in torque axis with no load on the motor and values relating to deadtime compensation from the drive. Measured values are used to calculate the current loop gains, and at the end of the test the values in Pr 00.038 and Pr 00.039 are updated. <p>To perform an autotune:</p> <ul style="list-style-type: none"> Set Pr 00.040 = 1 or 2 for a stationary autotune. (Both perform the same tests). Close the drive enable signal (terminal 29). Press the green <i>hand</i> button. The upper row of the display will flash 'Auto Tune' during the test. Wait for the drive to display 'Ready' or 'Inhibit'. <p>If the drive trips it cannot be reset until the drive enable signal (terminal 29) has been removed.</p> <ul style="list-style-type: none"> Remove the drive enable from the drive. | |
| Check Saliency | In sensorless mode, when the motor speed is below Pr 00.045 / 10, a special low speed algorithm must be used to control the motor. There are two modes available, with the mode chosen based on the saliency of the motor. The ratio No-load Lq (Pr 00.056) / Ld (Pr 05.024) provides a measure of the saliency. If this value is > 1.1, then Non-salient mode must be used (this is the default), otherwise Injection mode may be used. Set Pr 00.054 for the selected mode: Injection (0) or Non-salient (1). | |
| Save parameters | Select 'Save Parameters' in Pr mm.000 (alternatively enter a value of 1000 in Pr mm.000) and press red  reset button or toggle the reset digital input. | |
| Run | Drive is now ready to run | |

| |
|---------------------------|
| Safety information |
| Product information |
| Mechanical installation |
| Electrical installation |
| Getting started |
| Basic parameters (Menu 0) |
| Running the motor |
| NV / Media Card Operation |
| Further information |
| UL listing information |

7.3 Quick start commissioning / start-up using Powerdrive Connect (V02.00.00.00 onwards)

Powerdrive Connect is a Windows™ based software commissioning / start-up tool for Powerdrive F300. Powerdrive Connect can be used for commissioning / start-up and monitoring, drive parameters can be uploaded, downloaded and compared and simple or custom menu listings can be created. Drive menus can be displayed in standard list format or as live block diagrams. Powerdrive Connect is able to communicate with a single drive or a network. Powerdrive Connect can be downloaded from www.controltechniques.com (file size approximately 100 MB).

Powerdrive Connect system requirements

- Windows 8, Windows 7 SP1, Windows Vista SP2, Windows XP SP3
- Minimum of 1280 x 1024 screen resolution with 256 colours
- Microsoft.Net Frameworks 4.0 (this is provided in the downloaded file)
- Note that you must have administrator rights to install Powerdrive Connect

Any previous copy of Powerdrive Connect should be uninstalled before proceeding with the installation (existing projects will not be lost). Included within Powerdrive Connect is the *Parameter Reference Guide* for Powerdrive.

7.3.1 Power-up the drive

1. Start Powerdrive Connect, and on the 'Project Management' screen select 'Scan serial RTU network' or 'Scan all connected drives'.

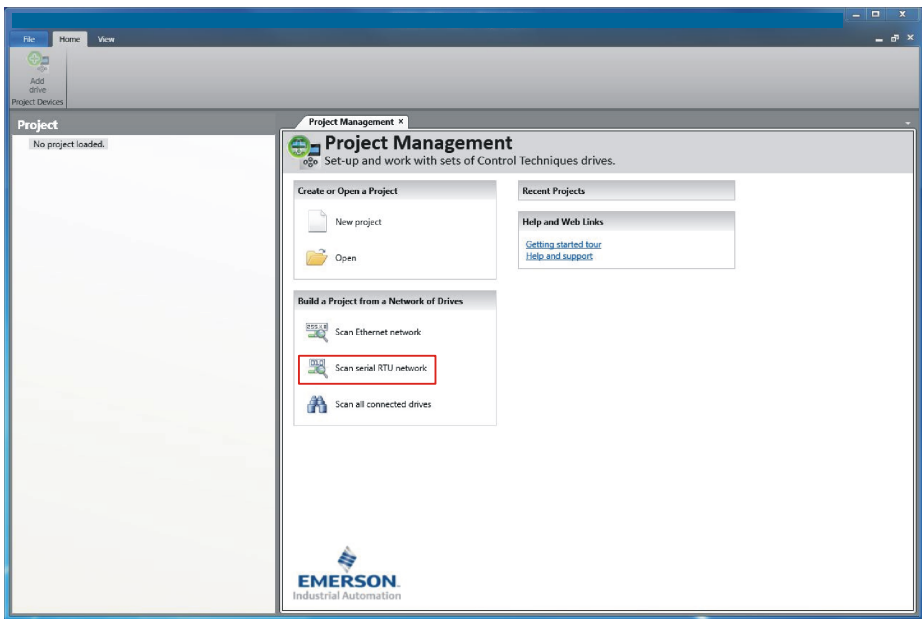

7.3.2 Select the discovered drive

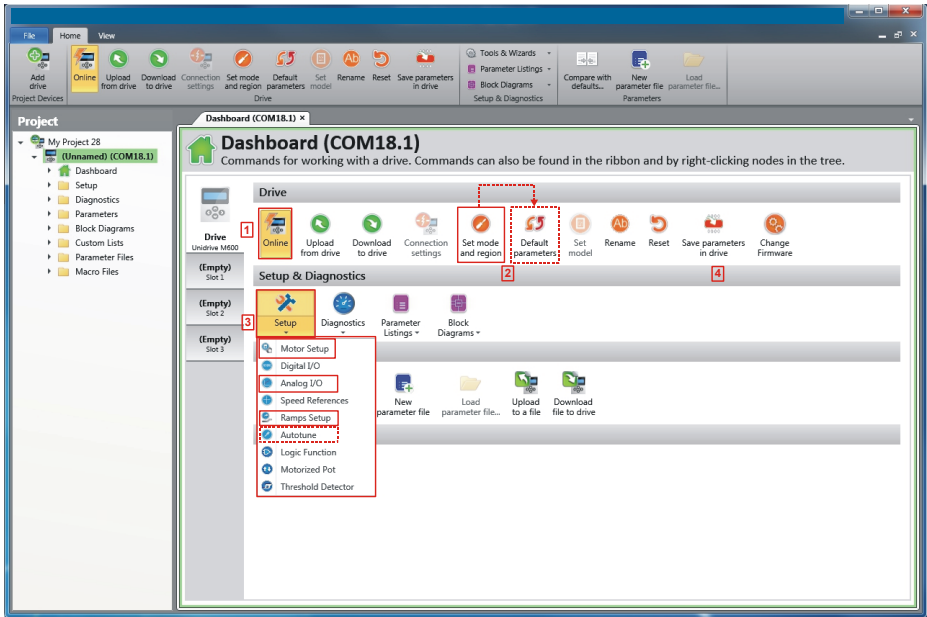

- Select the 'Online' icon to connect with the drive. When a successful connection is made the icon will be highlighted orange.
- Select 'Set mode and region'.
If the required control mode is highlighted in the 'Drive Settings' dialog, then:
 - Change the supply frequency, if required and select 'Apply', otherwise select 'Cancel'.
 - Select 'Default parameters' from the Dashboard and in the 'Default Parameters' dialogue, select 'Apply'
 If the required control mode is not highlighted in the 'Drive Settings' dialog then:
 - Select the required mode and supply frequency.
 - Select 'Apply'.
- Select 'Setup' and perform the steps highlighted (dotted lines indicate a step which may not need to be performed (see below):

| Action | Detail |
|-------------|---|
| Motor Setup | Powerdrive Connect contains a database for induction motors and permanent magnet motors. Provision is also made to enter motor nameplate data. The next section describes the use of the motor database for a Leroy Somer LSRPM motor used in RFC-S Sensorless mode. |
| Analog I/O | The motor thermistor can be selected in Pr 07.011 . Refer to the parameter help for Pr 07.011 for further information. |
| Ramps Setup | Enter the required Acceleration rate and Deceleration rate |
| Autotune | Not required when using data from the motor database for a Leroy Somer LSRPM motor used in RFC-S Sensorless mode. |

- Select 'Save parameters in drive' to perform a parameter save. The drive is now ready to run.

7.3.3 Use of the motor database for a Leroy Somer LSRPM motor for use in RFC-S Sensorless mode

- Select 'Motor Setup' from the 'Dashboard'.
- On the 'Motor Setup' screen, select 'Choose a motor'.

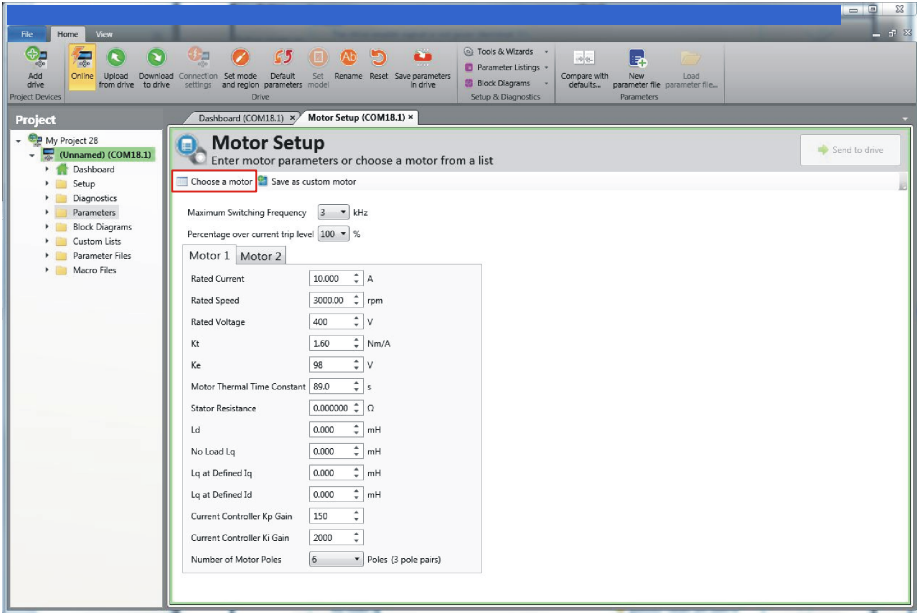

Select the required motor database:

7.3.4 Select the required motor from the list and click 'OK'

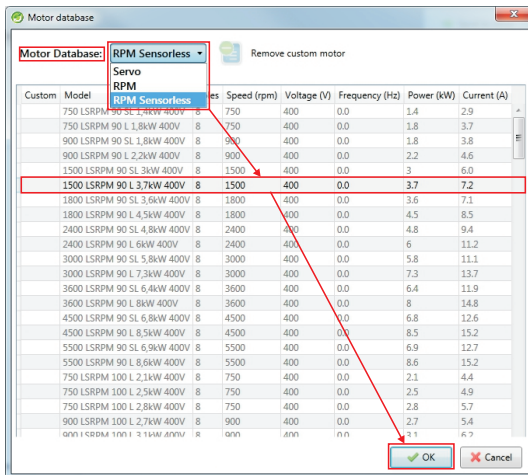

The data for the selected motor is displayed on the 'Motor Setup' screen. Click 'Send to drive' to set the associated parameters.

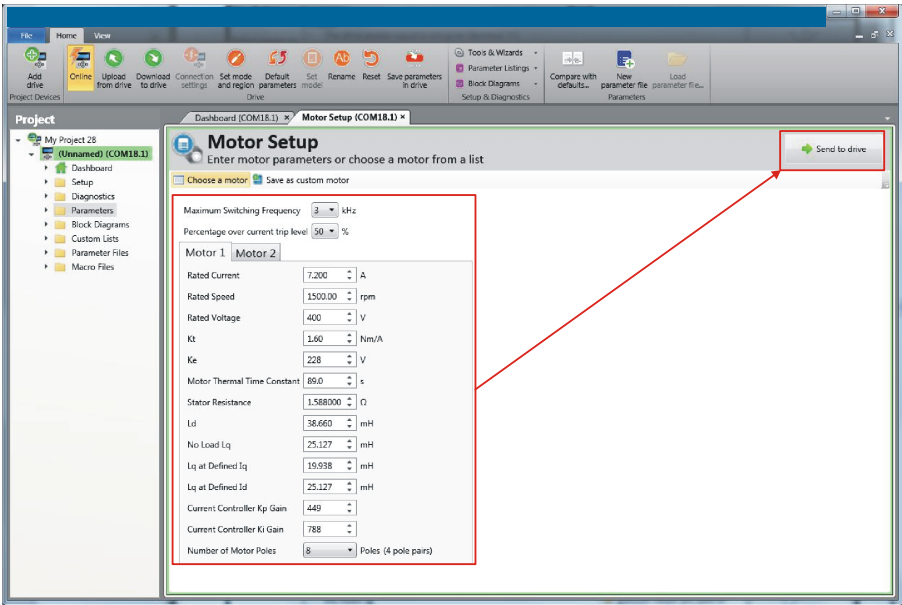

7.4 Diagnostics

If the drive trips, it is possible to interrogate the trip log from within Powerdrive Connect. Select 'Drive Trip Log' from the 'Dashboard'.

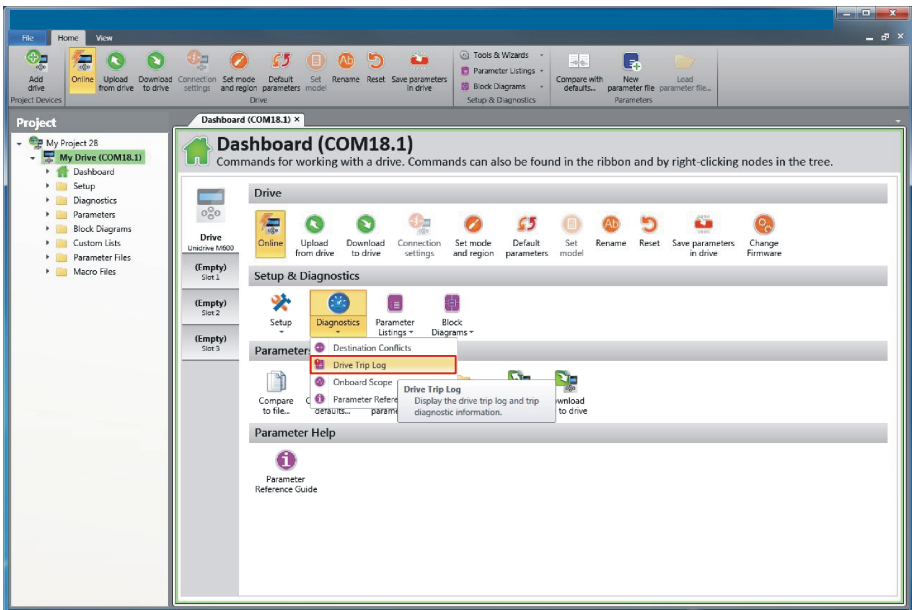

The drive trip log shows the trip responsible for stopping the autotune and a description of the trip.

The screenshot shows the 'Drive Trip Log' window in a software application. The window title is 'Drive Trip Log (COM18.1)'. It contains a table of trip events and a detailed view for the selected trip (Trip 1).

Drive Trip Log Table:

| Trip | Trip Code | Description | Date | Time | Sub-trip |
|------|-----------|------------------|-------|----------|----------|
| 1 | 18 | Autotune Stopped | Day 0 | 00:08:52 | 0 |
| 2 | 0 | None | Day 0 | 00:00:00 | 0 |
| 3 | 0 | None | Day 0 | 00:00:00 | 0 |
| 4 | 0 | None | Day 0 | 00:00:00 | 0 |
| 5 | 0 | None | Day 0 | 00:00:00 | 0 |
| 6 | 0 | None | Day 0 | 00:00:00 | 0 |
| 7 | 0 | None | Day 0 | 00:00:00 | 0 |
| 8 | 0 | None | Day 0 | 00:00:00 | 0 |
| 9 | 0 | None | Day 0 | 00:00:00 | 0 |
| 10 | 0 | None | Day 0 | 00:00:00 | 0 |

Trip 1 Details:

| | |
|-------------------|-------------------------|
| Trip | Autotune Stopped |
| Value | 18 |
| Short description | |

The drive was prevented from completing an auto-tune, because either the Final drive enable or the Final drive run were removed.

Recommended actions:

- Check the drive enable signal (Terminal 31) was active during the auto-tune.
- Check the run command was active in *Digital Input 05 State (08.006)* during the auto-tune.

8 NV Media Card Operation

8.1 Introduction

The Non-Volatile Media Card feature enables simple configuration of parameters, parameter back-up and drive cloning using a SMARTCARD or SD card. The drive offers backward compatibility for a Unidrive SP SMARTCARD.

The NV Media Card can be used for:

- Parameter copying between drives
- Saving drive parameter sets
- Saving a program

The NV Media Card is located at the top of the module under the drive display (if installed) on the left-hand side.

Ensure NV Media Card is inserted with the contacts facing the left-hand side of the drive.

The drive only communicates with the NV Media Card when commanded to read or write, meaning the card may be "hot swapped".

Figure 8-1 Installation of the NV Media Card

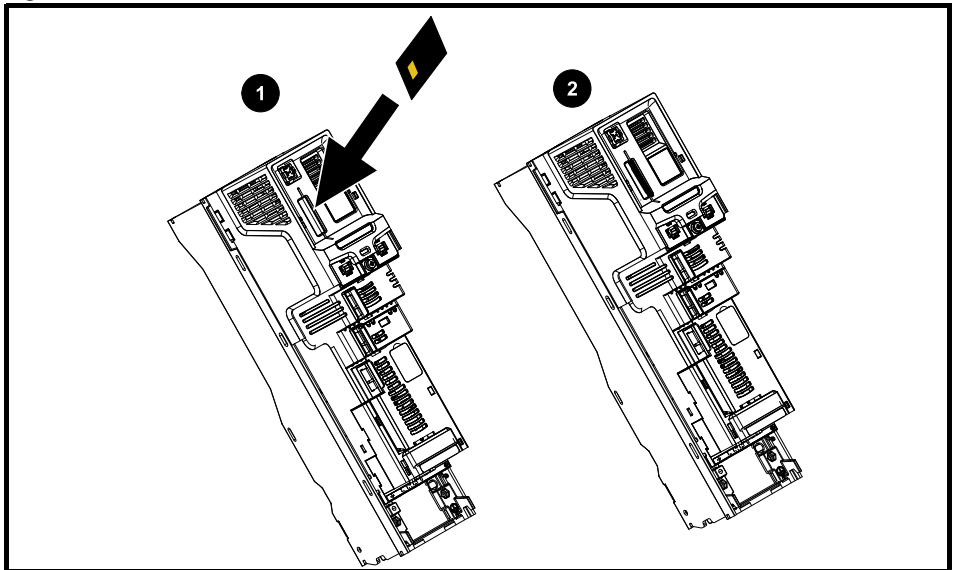

1. Installing the NV Media Card
2. NV Media Card installed

| NV Media Card | Part number |
|--|--------------|
| SD Card Adaptor (memory card not included) | 3130-1212-03 |
| 8 kB SMARTCARD | 2214-4246-03 |
| 64 kB SMARTCARD | 2214-1006-03 |

8.2 NV Media Card support

The NV Media Card can be used to store drive parameters and / or PLC programs set from the Powerdrive in data blocks 001 to 499.

The Powerdrive is compatible with Unidrive SP SMARTCARD and is able to read and translate the Unidrive SP parameter set into a compatible parameter set for Powerdrive. This is only possible if the Unidrive SP parameter set was transferred to the SMARTCARD using the difference from defaults transfer method (i.e. 4yyy transfer). The Powerdrive is not able to read any other type of Unidrive SP data block on the card. Although it is possible to transfer difference from default data blocks from a Unidrive SP into the Powerdrive, the following should be noted:

1. If a parameter from the source drive does not exist in the target drive then no data is transferred for that parameter.
2. If the data for the parameter in the target drive is out of range then the data is limited to the range of the target parameter.
3. If the target drive has a different rating to the source drive then the normal rules for this type of transfer apply.

Figure 8-2 Basic NV Media Card operation

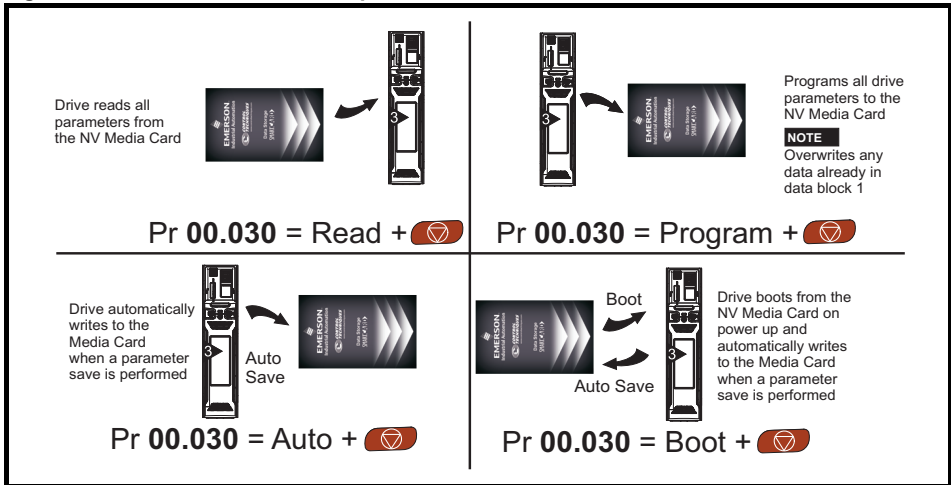

The whole card may be protected from writing or erasing by setting the read-only flag, refer to the *Drive User Guide* for further information.

The card should not be removed during data transfer, as the drive will produce a trip. If this occurs then either the transfer should be reattempted or in the case of a card to drive transfer, default parameters should be loaded.

8.3 Transferring data

Data transfer, erasing and protecting the information is performed by entering a code in Pr **mm.000** and then resetting the drive as shown in Table 8-1.

Table 8-1 SMARTCARD and SD card codes

| Code | Operation | SMARTCARD | SD card |
|-------|--|-----------|---------|
| 2001 | Transfer the drive parameters to parameter file 001 and sets the block as bootable. This will include the parameters from attached option modules. | ✓ | ✓ |
| 4yyy | Transfer the drive parameters to parameter file yyy. This will include the parameters from attached option modules. | ✓ | ✓ |
| 5yyy | Transfer the onboard user program to onboard user program file yyy. | ✓ | ✓ |
| 6yyy | Load the drive parameters from parameter file yyy or the onboard user program from onboard user program file yyy. | ✓ | ✓ |
| 7yyy | Erase file yyy. | ✓ | ✓ |
| 8yyy | Compare the data in the drive with file yyy. If the files are the same then Pr mm.000 (mm.000) is simply reset to 0 when the compare is complete. If the files are different a 'Card Compare' trip is initiated. All other NV media card trips also apply. | ✓ | ✓ |
| 9555 | Clear the warning suppression flag | ✓ | ✓ |
| 9666 | Set the warning suppression flag | ✓ | ✓ |
| 9777 | Clear the read-only flag | ✓ | ✓ |
| 9888 | Set the read-only flag | ✓ | ✓ |
| 9999 | Erase and format the NV media card | ✓ | |
| 40yyy | Backup all drive data (parameter differences from defaults, an onboard user program, applications programs and miscellaneous option data), including the drive name; the store will occur to the </MCDF/driveyyy/> folder; if it does not exist, it will be created. Because the name is stored, this is a backup, rather than a clone. The command code will be cleared when all drive and option data have been saved. | | ✓ |
| 60yyy | Load all drive data (parameter differences from defaults, an onboard user program, applications programs and miscellaneous option data); the load will come from the </MCDF/driveyyy/> folder. The command code will not be cleared until the drive and all option data have been loaded. | | ✓ |

Safety information

Product information

Mechanical installation

Electrical installation

Getting started

Basic parameters (Menu 0)

Running the motor

NV Media Card Operation

Further information

UL listing information

9 Further information

9.1 Diagnostics

For further information on diagnostics including trips and alarms, refer to the *Drive User Guide*.

10 UL listing information

10.1 General

10.1.1 Scope of approvals

All models are listed to both US and Canadian safety requirements.

The UL file number is: E171230.

The Manufacturing Location Code is: 8D14.

10.1.2 Manufacturers name

The manufacturer is Control Techniques Ltd

10.1.3 Electrical ratings

The electrical ratings are tabulated in the *Drive User Guide*.

10.1.4 Multiple wiring arrangements

The drives are not intended for use in applications that require different wiring arrangements. The drives are not multiple rated.

10.1.5 Model numbers

Model numbers are shown in the *Drive User Guide*.

10.1.6 Plenum rating

The drives are suitable for installation in a compartment (duct) handling conditioned air when installed as enclosed types with the intended Type 1 terminal kit.

10.1.7 Operating temperature

The drives are rated for use at 40 °C ambient temperature.

Operation at 50 °C is permitted with derated output. Refer to the *Drive User Guide* for further information.

10.1.8 Installation warnings, cautions and notes

The appropriate installation warnings, cautions and notes are located in Chapter 1 *Safety information* on page 5.

10.2 Overload, overcurrent and overspeed protection

10.2.1 Degree of protection level

The devices incorporate solid state overload protection for the motor load. The protection levels are expressed as a percentage of full-load current. Refer to the *Drive User Guide* for further information.

In order for the motor protection to work properly, the motor rated current must be entered into Pr **00.046** or Pr **05.007**.

The protection level may be adjusted below 150 % if required. Refer to the *Drive User Guide* for further information.

The drive incorporates solid state motor overspeed protection. However, this feature does not provide the level of protection provided by an independent, high-integrity overspeed protection device.

10.2.2 Thermal memory protection

The drives are provided with motor load and speed sensitive overload protection with thermal memory retention.

The thermal memory protection complies with UL requirements for shutdown, loss of power and speed sensitivity.

For a full explanation of the thermal protection system refer to the *Drive User Guide*.

In order to comply with UL requirements for thermal memory retention it is necessary to set the *Thermal Protection Mode* (Pr **04.016**) to zero; and the *Low Speed Protection Mode* (Pr **04.025**) must be set to 1.

10.2.3 Use with motors with thermal protectors

The drive is provided with a means to accept and act upon a signal from a thermal sensor or switch imbedded in the motor or from an external protective relay. Refer to the *Drive User Guide* for further information.

10.2.4 Specific overcurrent protective device

The drive is not required to be connected to a supply source with a specific overcurrent protective device other than those specified in section 2.3 *Ratings* on page 9.

10.3 Short-circuit protection for branch circuits

10.3.1 Short-circuit rating

The drive is suitable for use on a circuit capable of delivering not more than 100,000 RMS symmetrical amperes, 600 Vac maximum, when protected by the overcurrent protective devices as described in section 2.3 *Ratings* on page 9.

Unless otherwise indicated in the *Drive User Guide*, branch fuses may be any UL listed class CC, J or T rated 600 Vac.

Unless otherwise indicated in section 2.3 *Ratings* on page 9, circuit breakers may be any UL listed type with category control number DIVQ or DIVQ7, rated 600 Vac.

10.3.2 Solid state short-circuit protection

The drive is provided with solid state short-circuit protection. Integral solid state protection does not provide branch circuit protection. Branch circuit protection must be provided in accordance with the National Electrical Code and any additional local codes.

10.3.3 Short circuit protection for branch circuits (group installation)

Frame sizes 3, 4, 5 and 6 are approved for motor group installation on a circuit capable of delivering not more than 100,000 RMS symmetrical amperes, 600 V max, when protected by class CC, J, T or HSJ fuses".

10.3.4 Common DC bus systems

Frame sizes 3, 4, 5 and 6 are approved for use in modular drive systems using a common DC bus.

For permitted combinations of converter and inverter, along with the required branch circuit protection, contact Control Techniques.

10.4 Control circuit protection

10.4.1 Control circuit wiring

All control circuits are located in limited voltage, limited current isolated secondary circuits. Additional wiring protection is not required.

10.4.2 Supplemental fuse

When the control circuits are supplied with an external 24 V supply, a supplemental fuse is required as described in the *Drive User Guide*.

10.4.3 Accessory kit boxes

All drives are supplied with an accessory kit box, refer to the *Drive User Guide*.

10.5 Wiring terminal markings

10.5.1 Marking for proper connection

All main terminals are plainly marked. There are no multiple circuit arrangements.

10.5.2 Terminal connection of ground supply conductor.

The terminals for the connection of the grounded supply circuit conductor are identified by means of an earth symbol (IEC 60417, symbol No. 5019).

Ground connections must use UL listed closed loop (ring) terminals.

10.5.3 User relay contact

An isolated user relay contact is provided that may be wired in the field to become part of a class 1 or class 2 circuit. This is described in the *Drive User Guide*.

10.5.4 Type of conductors

Use copper conductors only.

10.5.5 Temperature rating of conductors

Use 75 °C rated conductors only.

10.5.6 Cable sizes for group installation

Frame sizes 3, 4, 5 and 6 are approved for motor group installation with input and output cable sizes restricted to 125 % of rated current.

10.5.7 Torque values

Torque values for field wiring terminals are provided in *section 3.6 Terminal size and torque settings* on page 20.

10.6 Environment

10.6.1 Environment

Drives are intended for operation in pollution degree 2 environments.

Drives are supplied as open type.

Drives are classed as Enclosed Type 1 when installed with the intended Type 1 terminal kit.

Drives are classed as Type 12 when installed in a Type 12 enclosure.

10.7 Mounting

10.7.1 Surface mounting

All drives are suitable for Surface mounting. Mounting instructions are given in *section 3.3 Mounting methods* on page 16.

10.7.2 Bookcase mounting

In order to minimize the width of the installation, drives may be mounted side by side with or without airspace between them.

10.7.3 Tile mounting

Frame sizes 3, 4 and 5 are suitable for Tile mounting. The drive is mounted sideways with the side panel against the mounting surface. Tile mounting kits are available.

10.7.4 Through-hole mounting

All models may be through-hole mounted. When through-hole mounted, inside a Type 12 enclosure, the high-IP insert (where provided) and the Type 12 sealing kit must be used in order to prevent ingress of dust and water. Refer to the *Drive User Guide* for further information.

10.8 Listed accessories

10.8.1 Option modules

The following option modules and accessories are UL listed:

Open Type:

| | |
|----------------|-------------------|
| SI-PROFINET RT | SI-I/O |
| SI-Ethernet | SD-Card Adaptor |
| SI-DeviceNet | KI-485 Adaptor |
| SI-CANopen | KI-HOA Keypad RTC |
| SI-PROFIBUS | |

NOTE Not all option modules are compatible with all drive models.

10.9 cUL Marking requirements

10.9.1 External transient suppression

Model numbers 07500530, 07500730, 8500860, 8501080 rated 575 V require external transient suppression in order to comply with cUL approval requirements:



CAUTION

Transient surge suppression shall be installed on the line side of this equipment and shall be rated 575 Vac (phase to ground), 575 Vac (phase to phase), suitable for overvoltage protection category III, and shall provide protection for a rated impulse withstand voltage peak of 6 kV and a clamping voltage of maximum 2400 V.

10.9.2 Opening of branch-circuit protection



WARNING

The opening of the branch-circuit protective device may be an indication that a fault has been interrupted. To reduce the risk of fire or electric shock, current-carrying parts, and other components of the controller should be examined and replaced if damaged.

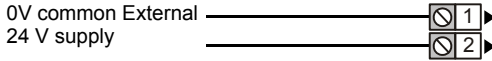
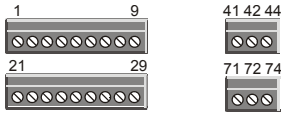

Analog frequency/speed reference 1 & 2

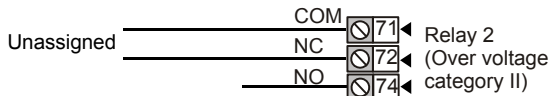
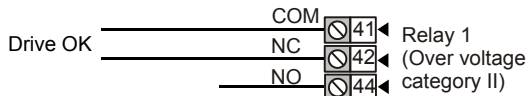
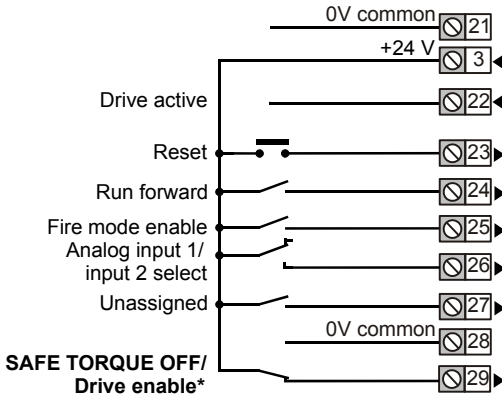
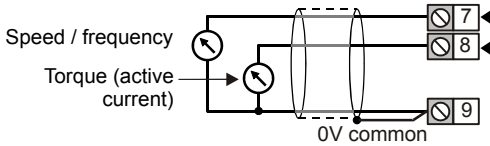
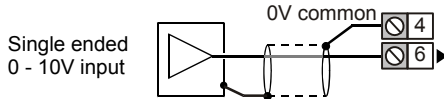
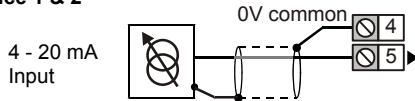

0479-0002-01